

# Owner's Handbook



**520i**  
**525i**  
**530i**  
**535i**  
**524td**



**BMW AG**

Bayerische Motoren Werke  
Aktiengesellschaft  
Munich

In the interests of continuing technical development, we reserve the right to modify designs, equipment and accessories.

Dimensions, weights and performance data quoted in this handbook are to the tolerances laid down by the German Institute for Industrial Standards (DIN).

Fuel consumption data are according to the values available at the time of closing for press.

Therefore, no claims based on data, statements, descriptions or illustrations in this handbook will be entertained.

Errors and omissions excepted.

Please note that this owner's handbook also describes additional equipment as far as this is relevant to correct operation.

Any discrepancies between your BMW and the details given here may be due to the equipment specification offered on a particular model or the items ordered with the car.

For a description of special equipment items not included in this handbook, refer to the installation or operating instructions provided. The BMW Service Organisation will be pleased to help in cases of doubt.

In the interests of operational reliability, vehicle safety and a high resale value, refrain from modifying the vehicle's specification in such a way that individual items no longer comply with the general operating permit or the model specification no longer applies.

### **Important information for your safety**

**For your own safety, use only parts and accessories approved by BMW.**

When you use accessories tested and approved by BMW and Original BMW Parts, you have the assurance that their suitability for your vehicle has been thoroughly tested by BMW. BMW bears full product responsibility for these items.

**BMW cannot entertain any liability for any parts and accessories not approved by BMW.**

BMW cannot test whether every product from other manufacturers can be used on a BMW safely and without risk to either the vehicle or the people it is carrying. Moreover, this guarantee cannot normally be provided by the general operating permit for the part or accessory in question, as tests cannot cover all eventualities.

Original BMW Parts, BMW Accessories and other products approved by BMW, together with experienced advice on using these items, are available from all authorised BMW dealers.

© 1988 Bayerische Motoren Werke (BMW) AG  
Munich, Federal Republic of Germany

Not to be reproduced wholly or in part  
without written permission from  
BMW AG, Munich

Order No. 01 41 9 780 731  
Englisch 1/88  
Printed in the Federal Republic of Germany aum

---

Congratulations on your choice of a BMW.

The better you are acquainted with your car, the easier you will discover driving to be. We therefore request you to heed the following piece of advice:

This owner's handbook contains important information on operating and looking after your BMW. Please read it carefully before setting out in your new car, so that you are fully familiar with the technical advantages of your BMW. It also contains useful information on care and maintenance, to maintain both the car's operating safety and its full resale value.

Wishing you many an enjoyable and safe journey,

**BAYERISCHE MOTOREN WERKE AKTIENGESELLSCHAFT**

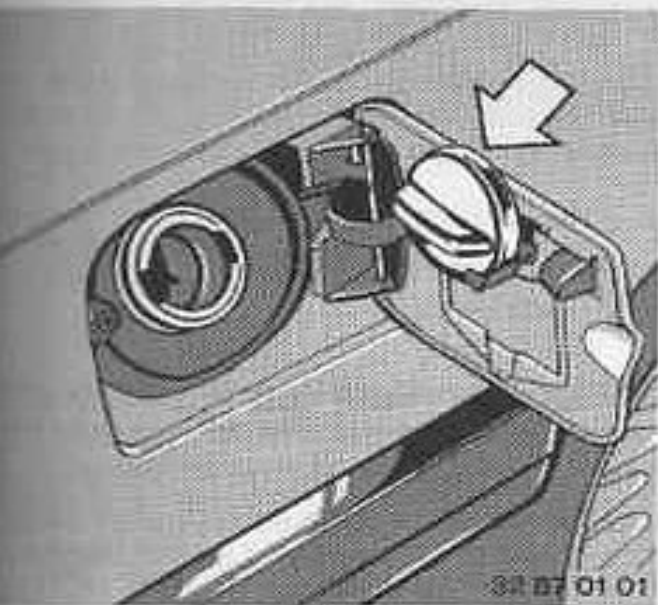

## Fuel grades

### Catalyst-equipped cars

Use **unleaded regular** fuel for spark-ignition engines to DIN 51 607 standard or equivalent, minimum octane number 91 (RM).

### Cars without catalytic converter\*

Use **all** fuels for spark-ignition engines (leaded or unleaded), minimum octane number 91 (RM).

### BMW 520i ECE version

Use **unleaded premium** fuel for spark-ignition engines to DIN 51 607 standard or equivalent, minimum octane number 95 (RM) (EurosUPER) or **premium** fuel for spark-ignition engines to DIN 51 600 standard or equivalent, minimum octane number 98 (RM) or **premium** fuel with minimum octane number 95 (RM).

In each case, a methanol content of up to 15% is permissible.

\*Catalytic converter can be retrofitted

### BMW 524td

Use **Diesel** oil to DIN 51 601 standard, minimum cetane number 45.

Never use marine diesel fuel, heating oil or similar grades in the car's diesel engine.

For winter operation, see page 79.

### Adding fuel

To open the fuel filler, turn the cap counter-clockwise and take it off.

To close the fuel filler, place the cap on the filler and turn it clockwise until it engages (bayonet-type catch).

### Catalyst models

To avoid the risk of leaded fuel being added to the tank, the filler pipe has a smaller diameter than on cars without a catalyst, and also a check valve.

A special funnel is available for adding fuel from a fuel can.

To open the fuel filler if the central locking system fails:

- lift up the right floor mat.
- take off the right section of the luggage compartment trim.
- push back the lock bar (arrow).

### Further checks:

see Page

- Tyre pressures (including the spare wheel), twice a month 111, 112
- Engine oil level 62
- Battery acid level (add distilled water if necessary) 66
- Coolant level 65
- Brake fluid level 64
- Vehicle lights (renewing bulbs) 75
- Cleaning fluid for the windscreen, headlight and fog light washers and intensive cleaning system 65

Operating instructions

Practical hints

Care of the car

Technical data

Index

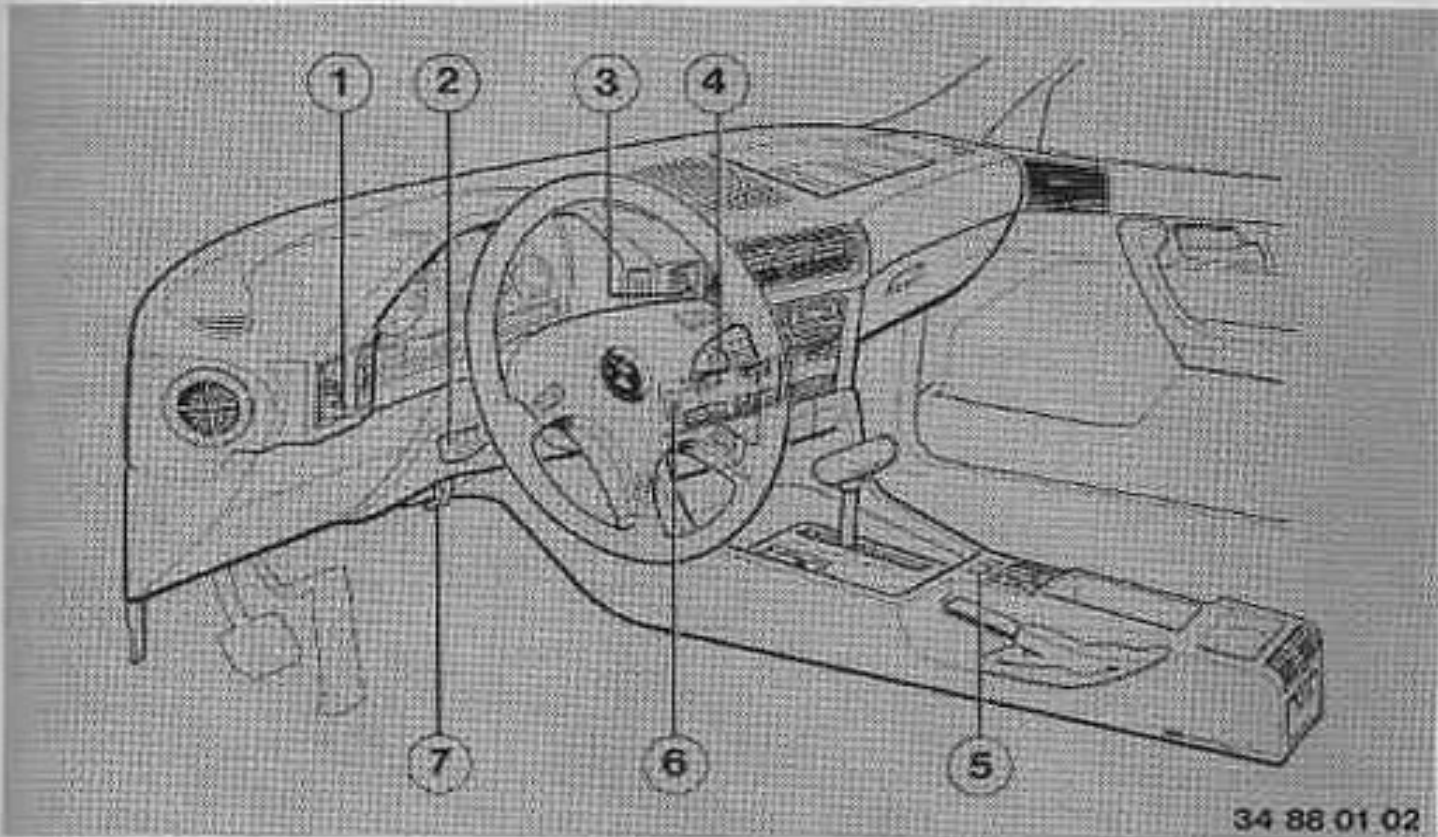

34 88 01 02

**Main controls**

	Page
1 - Headlight switch	17
2 - Lever for turn indicators, parking lights, low/high headlight beams and headlight flashing	19
3 - Fog light switch	26
4 - Wipe/wash lever	19
5 - Hazard warning flashers	26
6 - Rear window heater	26
7 - Steering column adjusting lever	13

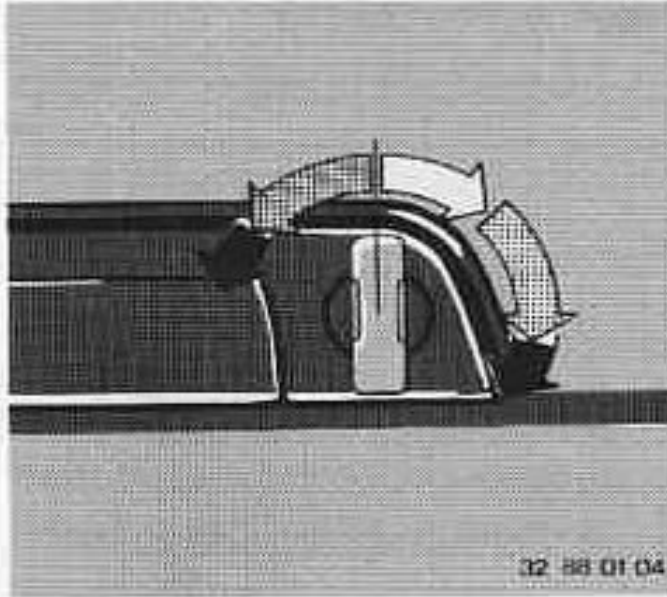
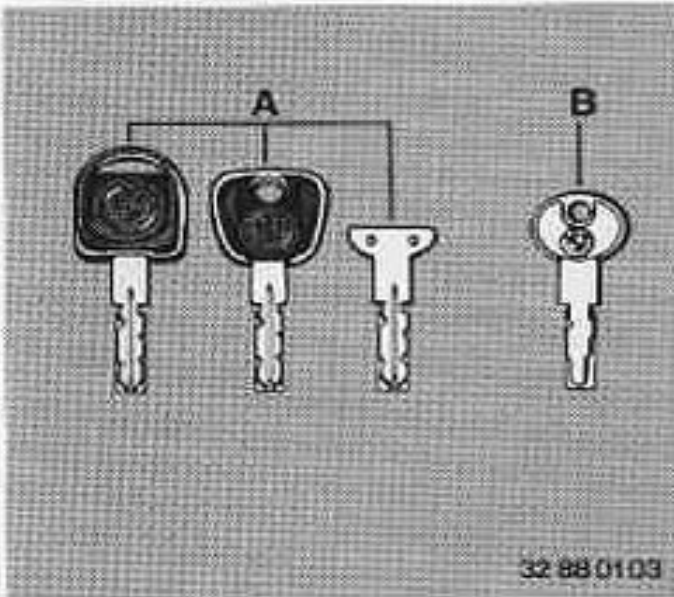

sliding/vent sunroof: hold the key in one of the two closing positions until all the windows and the roof are closed.

← **Central locking and  
thiefproofing device – opening**  
 → **Emergency operation  
in the event of failure of the electrical  
system**

Opening: lift the handle plate, turn the key in the opening direction beyond the pressure point.

To close again: turn the key beyond the central locking pressure point.

Note: if any door catch should not be retracted when locked according to the normal procedure, open the door according to the emergency procedure and lock it as described above.

**Opening the doors from the outside:**  
Lift up the handle plate.

**Driver's door lock heater:**

The heater is switched on when the handle plate is lifted. The heating time is automatically controlled to save energy.

**Opening the doors from the inside:**

First lift up the safety catch button if necessary, then pull the handle above the armrest. When the driver's door is open, its safety catch button cannot be pressed down; this is to avoid being locked out of the car accidentally.

**Important note:**

Children left in the car could lock the doors from the inside. To prevent this, make a point of removing the ignition key and taking it with you, so that the doors can be unlocked again from the outside.

## Keys

### A – Master key

- Main key with battery and light in key head (press BMW emblem to operate). Renew the battery when the light becomes dim, or else acid may leak out.
- Spare key.
- Duplicate key for safe keeping, e.g. in wallet or purse.

### B – Door and ignition key

Does not fit the luggage compartment or glove box locks.

Note: this key does not operate the central locking system inhibit device.

In case you need further or replacement keys, a self-adhesive label bearing the key number is provided. Keep this label in a safe place to safeguard against theft of the car.

### → **Central locking system – activating**

Whenever a door lock or the luggage compartment lock is operated or the safety catch button on the driver's door is pressed down, the luggage compartment lid and fuel filler flap locks are all locked.

The locks operated by the central locking system are released automatically in the event of a collision, and the hazard warning flashers and interior lights are switched on.

### → **Thiefproofing device – activating**

Turn the key in a door lock: the doors are then locked and the central locking system is out of action.

The key can only be removed when vertical. Note: since it cannot be released from inside the car, do not operate the central inhibit lock if there are still passengers in the car.

**Convenience circuit for windows and**

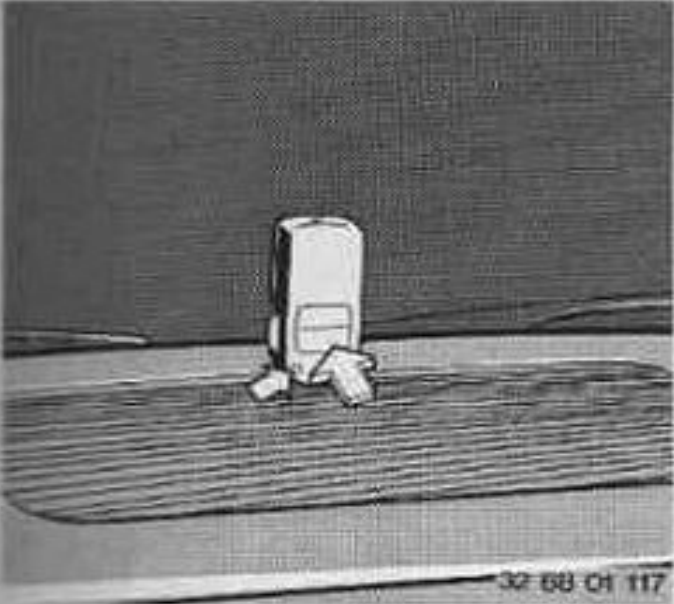

32 68 01 117

**Transmitter initialising is necessary**

- after renewing the transmitter battery, unless this takes less than one minute and none of the buttons are pressed)
- if a new key has been obtained.

The initialising procedure can be repeated as often as necessary.

**Changing the key blade**

If the infra-red remote control unit should develop a fault, replacements without a key blade are available from your BMW dealer.

To transfer the key blade to the new transmitter, remove the screw and take out the blade, insert it in the new transmitter and secure with the screw.

**Initialising the transmitter**

- Turn on the ignition with a second key (to position 2).
- Place the infra-red transmitter on the initialising unit (see picture).
- Press button 1 until the transmitter LED begins to flash (after about 2 seconds), initialising is then completed.

Within 15 minutes, any other transmitters used for the car (up to four are possible) must also be initialised.

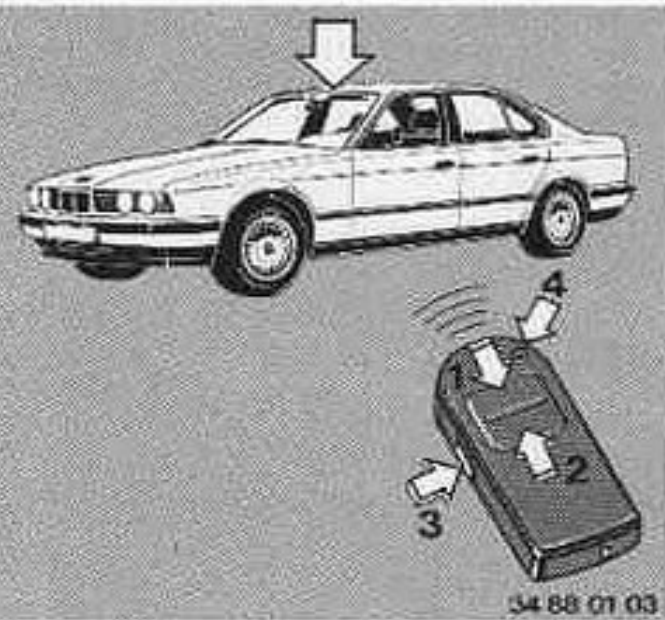

### **Infra-red remote control** (in preparation)

Point the transmitter at the receiver behind the car's interior mirror (max. 6 metres away). The beam must reach the receiver directly.

**If button 1 is pressed briefly** – LED (4) will come on for a short time

- The central locking system and central inhibit lock are then released
- The burglar alarm is de-activated
- The car's interior light is switched on

**If button 2 is pressed briefly** – the LED will come on for a short time:

- The central locking system is activated (car locked)

Within 15 seconds of having pressed button (2):

**If button 3 is pressed briefly** – the LED will come on for a short time:

- The central inhibit lock is engaged
- The burglar alarm is activated

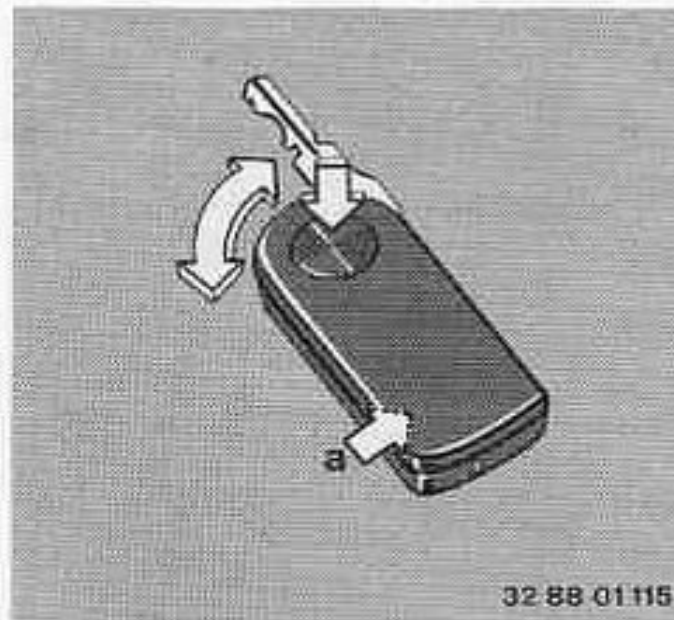

### **Closing windows and sunroof:**

Press button 2 or 3 and hold in – the LED will flash.

The closing movement is interrupted at once if the button is released.

### **Master key**

Press the button to fold the key out or retract it.

All functions at the door and luggage compartment locks can also be operated with the conventional keys (see Page 7).

### **Battery capacity**

Renew the battery if the LED does not come on when a button is pressed, and closing movements cannot be performed.



### **Renewing battery**

Remove screw (arrow "a"). Press the button and swing the cover to one side. Remove screw (arrow "b").

The correct battery type and installed position are printed on the battery holder.

**Important:** use only batteries of the specified type. Avoid environmental pollution when disposing of old batteries

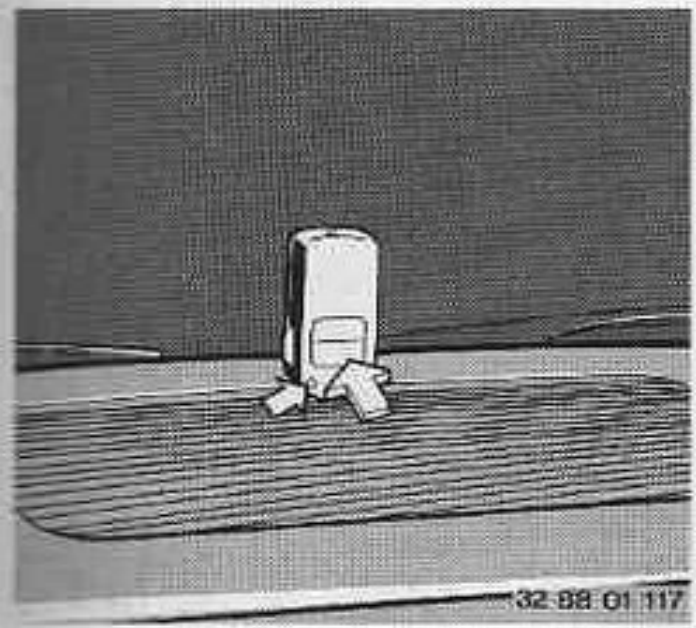

32 98 01 117

**Transmitter initialising is necessary**

- after renewing the transmitter battery, unless this takes less than one minute and none of the buttons are pressed)
- if a new key has been obtained.

The initialising procedure can be repeated as often as necessary.

**Changing the key blade**

If the infra-red remote control unit should develop a fault, replacements without a key blade are available from your BMW dealer.

To transfer the key blade to the new transmitter, remove the screw and take out the blade, insert it in the new transmitter and secure with the screw.

**Initialising the transmitter**

- Turn on the Ignition with a second key (to position 2).
- Place the infra-red transmitter on the initialising unit (see picture).
- Press button 1 until the transmitter LED begins to flash (after about 2 seconds). Initialising is then completed.

Within 15 minutes, any other transmitters used for the car (up to four are possible) must also be initialised.

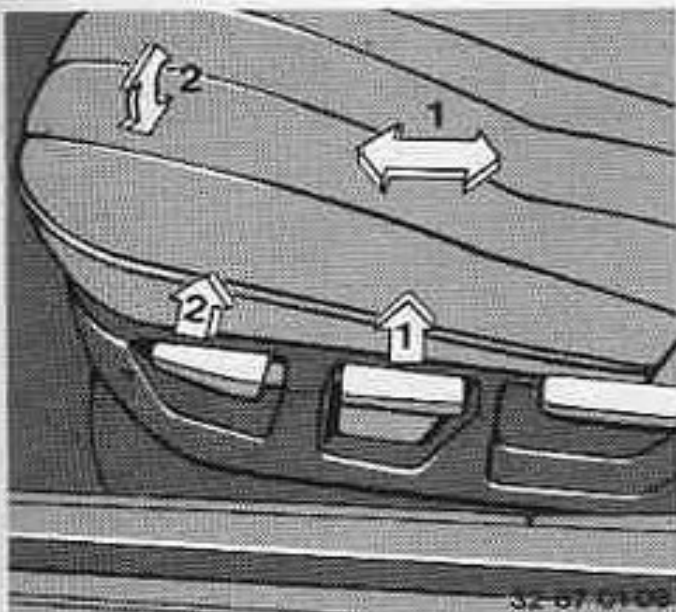

32 87 01 09

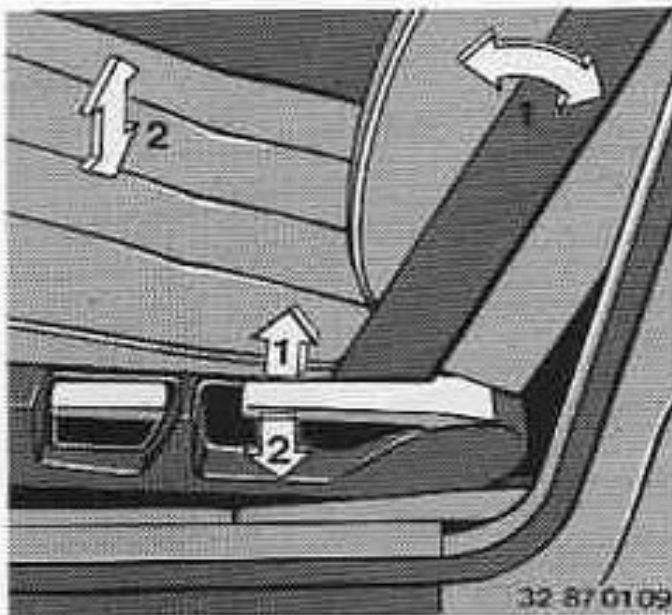

32 87 01 09

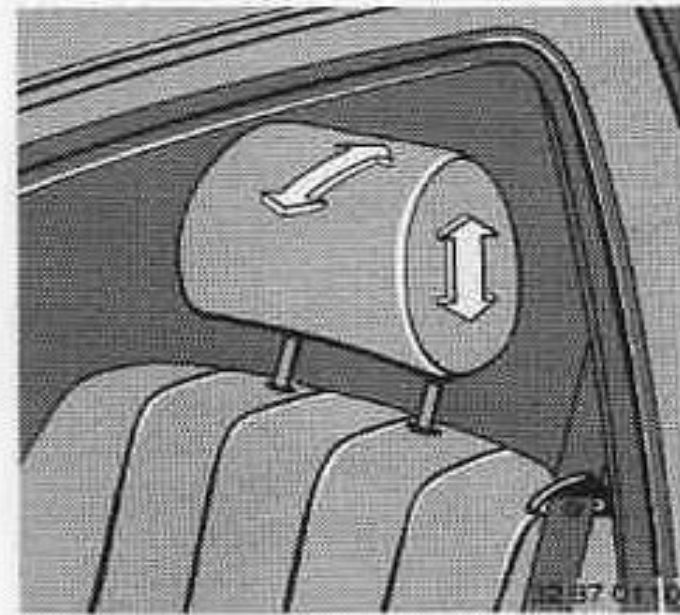

32 87 01 10

## Seats

### Moving seat forward/back

Pull lever (1) and push the seat to the desired position. After releasing the lever, make sure that the seat engages in its catches.

### Angle of complete seat

Pull lever (2) and move the seat as required.

### Seat back adjustment

Pull lever (1) and apply weight against the seat back or allow it to come forward.

### Seat height adjustment

Press lever (2). Apply weight to seat or allow it to come up as required.

**Electrical seat adjustment:** see Page 12.

### Front and rear head restraints

To alter the height, pull up or push down as required. Pivot forward or back to adjust the angle.

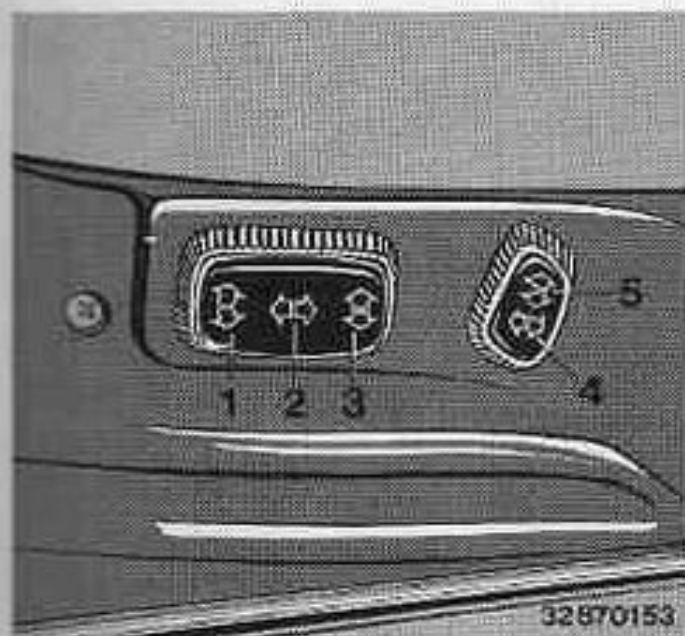

### **Electric front seat adjustment**

- 1 - Seat angle adjustment
- 2 - Forward/back seat movement
- 3 - Seat height adjustment
- 4 - Seat back angle adjustment
- 5 - Head-restraint height adjustment

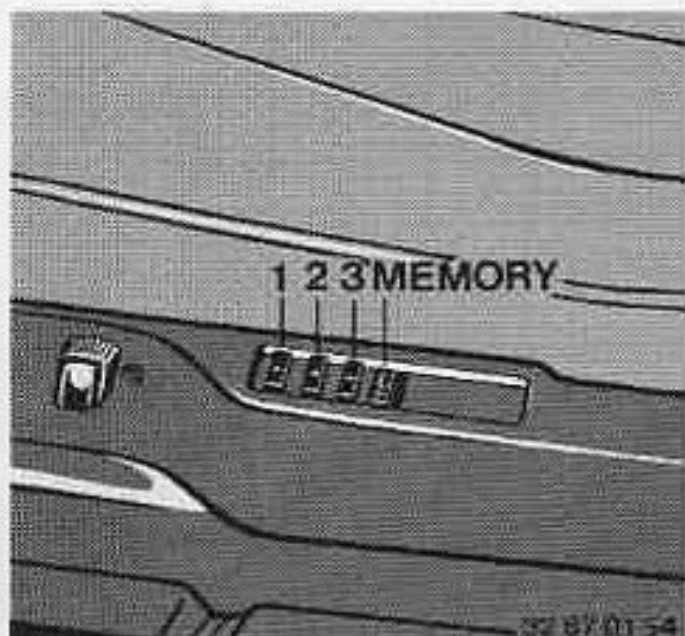

### **Seat and mirror memory**

Three different seat and mirror positions (both door mirrors) can be programmed and selected when required.

#### **Programming** (ignition key position 1 or beyond):

- Move seat and mirrors to the desired positions.
- Press the MEMORY button; the telltale lamp shows readiness for programming.
- Press button 1, 2 or 3 to store these settings.

#### **Selecting:**

With the driver's door open or with the door closed but the automatic interior light still on or the ignition key turned to position 1:

Press the desired button 1, 2 or 3 briefly.

The automatic movement process is interrupted as soon as a seat or mirror control switch or the memory keys are operated.

With the driver's door closed and the ignition key either removed or in position 0 or 2:

Press the desired button 1, 2 or 3 until the resetting procedure has been completed.

Mirror changeover switch (see Page 16) in driver's door mirror position:

when reverse is selected, the passenger's side door mirror glass tilts down slightly to show the road alongside and behind the near side of the car (edge of kerb etc.), as an aid when parking.

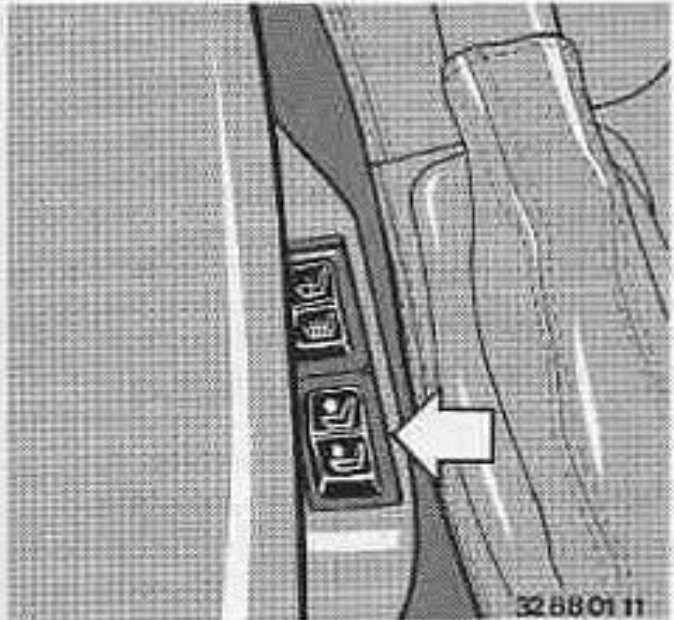

**Lumbar support**

Press rocker switch on inner side of seat frame to adjust to the required position.

This facility enables you to extend or retract the convex support in the seat back for the lower spine.

This provides support for the upper pelvis and spine, to enable a relaxed sitting position.

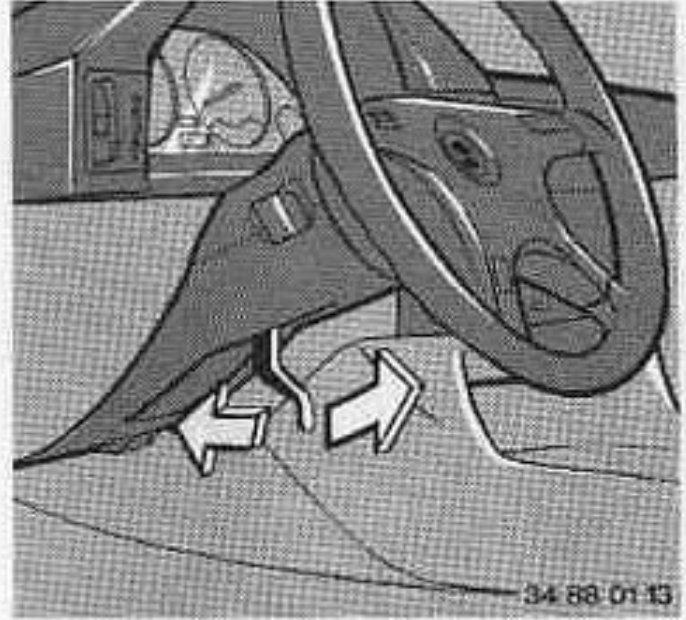

**Steering column adjustment**

Fold out the clamp lever. Pull out or push in the steering wheel to adjust its position in relation to the seat. Fold the clamp lever back in.

**Warning:** do not adjust position of the driver's seat or steering column while driving.



### Seat belts

Always wear the seat belts.

The lock must be heard to engage when the belt is inserted.

To release the lock, press the red button on the catch.

**Automatic seat belt release** (in preparation):

When the ignition key is removed at the end of a journey, the driver's belt catch will be opened.

Place the belt across the pelvis and shoulder, making sure that it is not twisted (do not pass the belt over hard or breakable objects in your pockets or clothing). The belt adjusts itself according to body movements.

It should just be possible to insert a hand between the belt and body. Therefore, avoid wearing thick and heavy clothing and do not tilt the seat too far back. Take up slack regularly by pulling up the belt at the shoulder.

The height of the upper belt anchorage point is automatically adjusted as the seat is moved forward and back, to suit occupants of various heights.

#### Note in particular:

The belt locking mechanism may operate when:

- the belt is pulled too fast
- the car is braked or accelerated abruptly
- taking corners, and
- the car is at a steep angle.

Only one person (over six years old or as permitted by law) must be secured by each seat belt. Make sure that the upper belt does not pass over the neck.

The belt must not become jammed or rub against sharp edges.

If the belts or the **BMW child restraint system** are subjected to severe stresses in an accident, have them renewed and the anchoring points examined by a BMW service station.

Do not tamper with any occupant restraint system.

**Care of the seat belts** is described in the chapter headed "Care of the car".

#### Notes on driver's seat position

The spine obtains most relief when you sit right back in the seat and rest against the seat back.

Ideally, the driver's head should be on a straight line forming a direct extension of the spinal column.

On long journeys the seat back angle can be increased slightly to reduce further the strain on the body muscles. However, the driver must still be able to reach the full circumference of the steering wheel with the arms slightly bent.

#### Head restraints

The head restraints must be positioned behind the head, not the neck.

## Airbag restraint system

This safety system comprises the airbag located inside the steering wheel, the gas generator, impact sensors on both sides in the front section of the car, the belt tensioning elements and the electronic monitoring system with safety sensor in the passenger compartment.

### AIRBAG telltale lamp in combined instrument

The telltale lamp comes on to indicate that the system is operational when the ignition key is in position 1 or beyond.

#### System operational:

The AIRBAG inscription comes on for about 6 seconds and then goes out.

#### System faulty:

- inscription does not come on,
- inscription goes out briefly after about 6 seconds and then comes on again.
- inscription flashes during a journey for app. 5 mins, then remains on.

In all these cases, there is a risk of the system not operating in the event of an accident.

For your own safety, have the system checked immediately by a BMW service station.

### Operating principle

The airbag, located beneath the padded steering wheel cover, inflates and breaks through at the designed rupture points. When fully inflated over the steering wheel, it slows down forward movement of the driver and protects the upper part of the body.

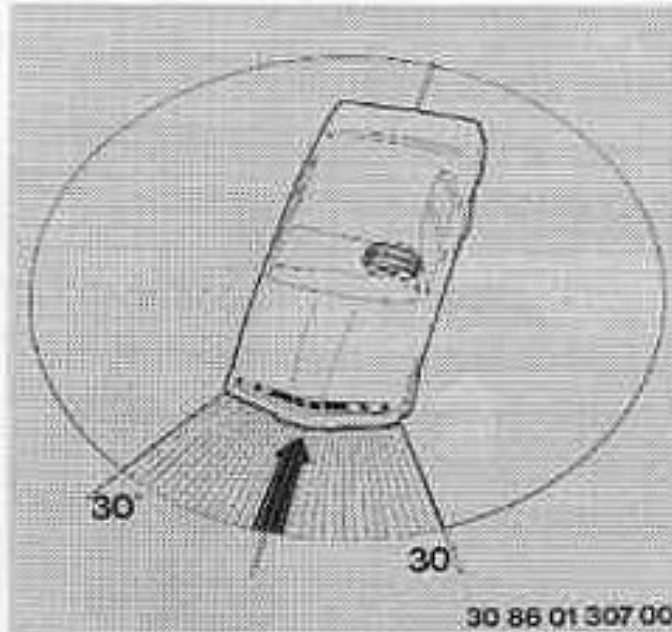

The whole process takes only a fraction of a second.

When the airbag inflates, the driver does not register any impact: in fact ignition, the loud noise of bag inflation and subsequent deflation occur so rapidly that the process is scarcely noticed while the accident is occurring.

The airbag system is designed to operate only in the event of a front-end collision with a fixed obstruction at a minimum speed of 20 km/h (12.5 mile/h), or with a resilient object at a correspondingly higher speed.

The diagram illustrates the impact range designed to activate the airbag system.

In minor collisions, if the car rolls over or in the event of a side-swipe or rear-end collision, the seat belts are the sole means of protection.

## The airbag is not a substitute for wearing a seat belt

When the system is activated, small amounts of smoky fumes are released together with the inflating gas. These fumes are not harmful and do not indicate that there is a fire in the vehicle.

No alterations must be made to the individual components and cables. This includes the padded panel on the steering wheel, which must not be treated with adhesive, covered, altered or adjusted in any other way, and the steering wheel, which must not be removed.

Work on the airbag must only be carried out by authorised BMW personnel.

Work carried out in an incorrect manner may cause the system to fail or be activated unintentionally, or could result in injury.

If the airbag generator or belt tensioning generator are scrapped, it is essential to follow the BMW safety guidelines, which can be consulted at any BMW service station. To ensure reliable operation over an extended period, comply with the inspection intervals stated on the adhesive label in the glove box.

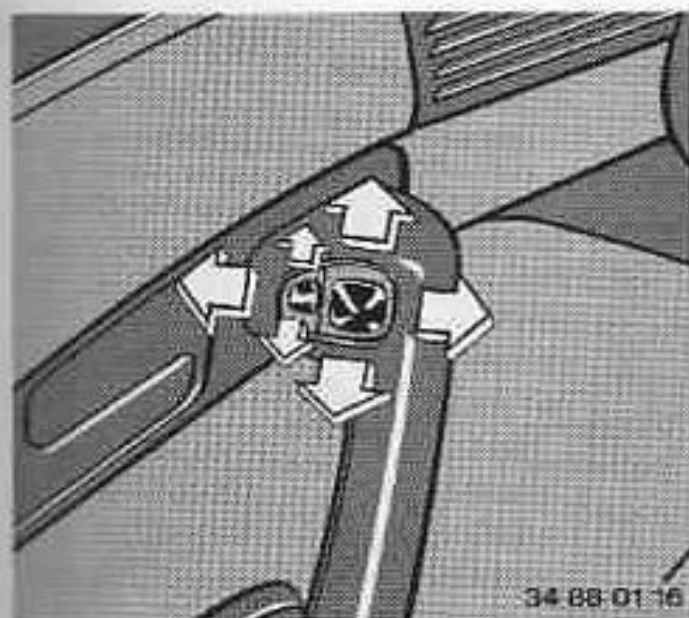

### Door mirrors

#### Electric remote-control door mirror

Operate the mirror switch to reposition the mirror as necessary.

#### Electric mirror heating

The heating element comes on and is controlled automatically.

#### Passenger's door mirror

Operate the changeover switch and then the mirror switch to move this mirror to the desired position.

#### Manual mirror operation

Reposition the mirror by moving the glass at the edges.

For mirror memory, see Page 12.

#### Aspherical wide-angle mirror

The outer section of the mirror is convex and reflects an enlarged, but slightly distorted, area behind the car. The inner section of the mirror reflects the normal rear-view area.

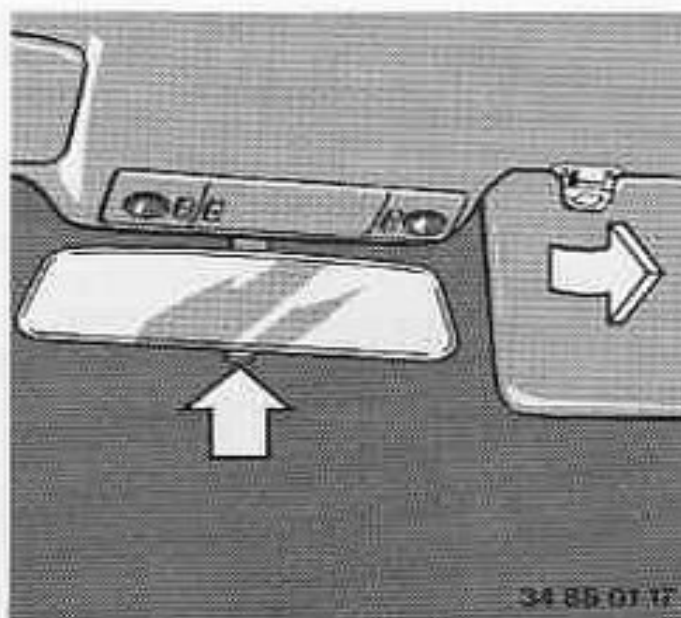

This improves the driver's range of rearward vision and eradicates the "blind spot" at the rear and side of the car.

#### Inside mirror

Move the small lever to reduce the effect of glare from following cars' headlights when driving at night.

When the roller sun blind is pulled up, the view in the inside mirror is adversely affected.

Note national regulations in this respect, and fit a second door mirror if required.

#### Sun visors

These can be pivoted in front of the side windows if necessary.

#### Make-up mirror with light

The light comes on when the sun visor is folded down and the car's lights are on. Slide the cover to one side as necessary.

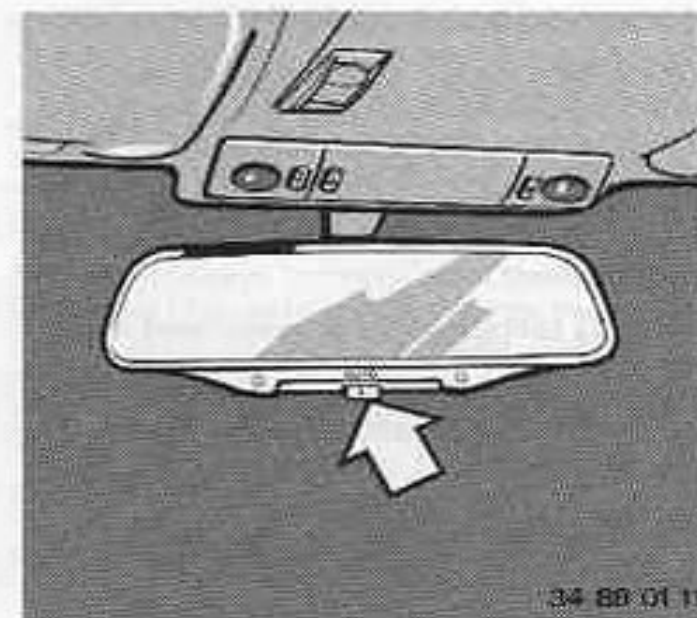

#### Automatic-dip inside mirror (in preparation)

Adjust sensitivity at slide:

Centre position (detent): normal sensitivity.

Slide moved to left: decreased sensitivity.

Far left: mirror does not dip automatically.

Slide moved to right: increased sensitivity.

Far right: mirror permanently dipped.

When the mirror is dipped, the green LED lights up.

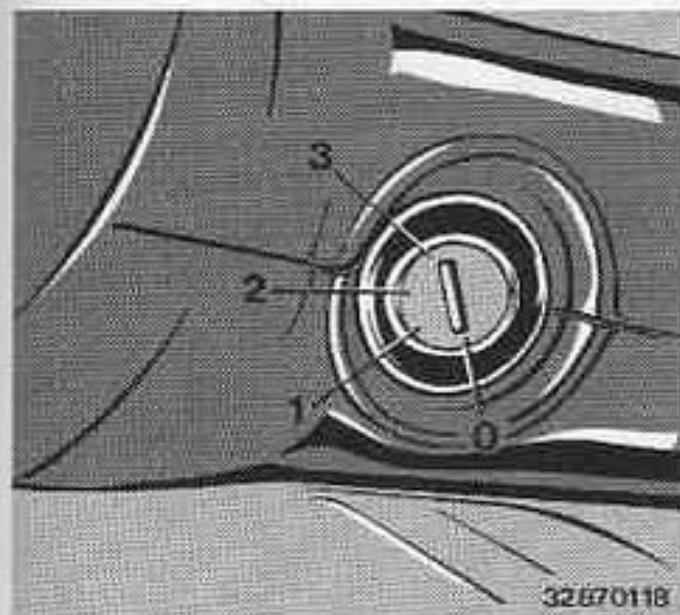

### Ignition/starter switch and steering lock

- 0 – Steering locked.  
The key can be inserted and removed in this position only.

All items of electrical equipment are switched off except for the following: side/parking lights, interior lighting, hazard warning flashers, electric seat adjustment, cigarette lighter.

To lock the steering, pull out the key and turn the steering wheel slightly until the lock engages.

To release the steering lock, it may be necessary to turn the steering wheel slightly.

- 1 – Steering unlocked.  
Further electrical equipment such as the radio and on-board computer can be operated.
- 2 – Ignition switched on.  
All other items of electrical equipment can be operated.
- 3 – Starter motor operated.  
**DO NOT DEPRESS THE ACCELERATOR PEDAL WHILE STARTING THE ENGINE.**

### Important notes

**Never run the car's engine in an enclosed space.**

The exhaust contains carbon monoxide which, although colourless and odourless, is extremely toxic.

**Never pull out the ignition key when the car is moving.**

Otherwise, the ignition lock will engage and make it impossible to steer the car.

**Always remove the ignition key and take it with you when leaving the car. Make sure that the steering lock has engaged.**

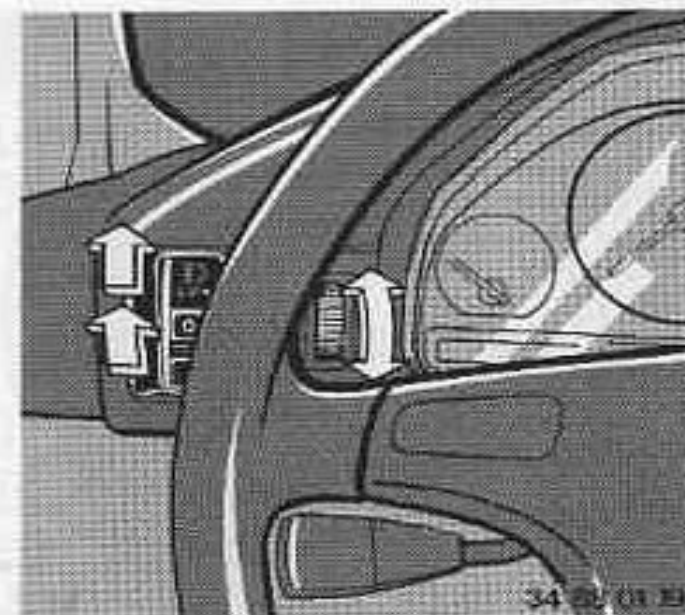

### Main light switch

- Stage 1: side lights  
Stage 2: low headlight beams

If the ignition is switched off with the headlights on, they will go out, but the sidelights will remain on.

### Instrument lighting

Turn the knurled wheel to adjust the light intensity.

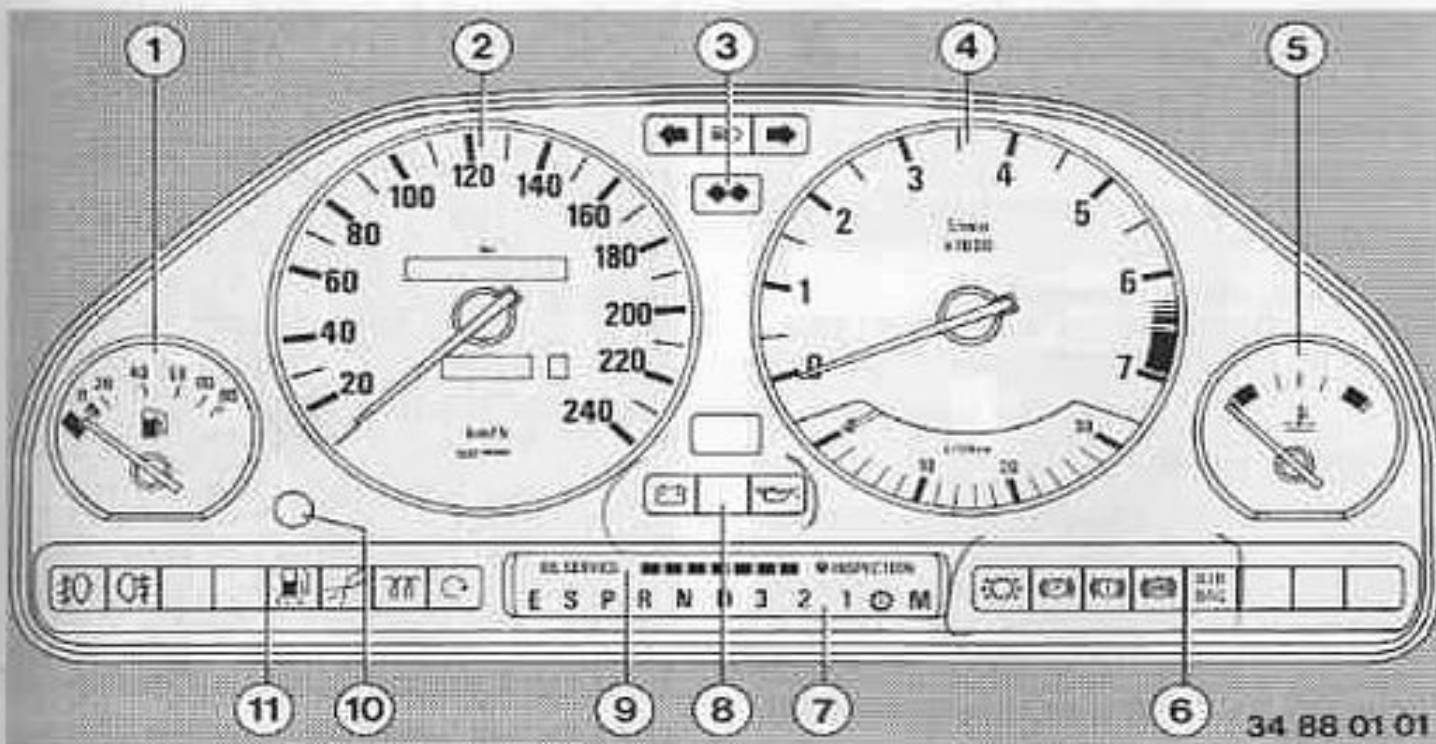

### Instrument cluster

	Page
1 - Fuel gauge with telltale	22
2 - Speedometer with total and trip distance recorders	21
3 - Turn indicator, high beam and trailer flasher telltales	23
4 - Revolution counter with Energy Control	21
5 - Coolant temperature gauge	22
6 - Telltale and warning lamps for brake lining wear, handbrake, brake hydraulics, antilock brake system (ABS) and AIRBAG	23,15
7 - Automatic transmission selector lever position lamps and program display; with electronic-hydraulic control, also program indicators and telltale for selector electronics	28
8 - Battery charge and oil pressure telltales	23
9 - Service Indicator	22
10 - Reset knob for trip distance recorder	21
11 - Front and rear fog light telltales; additionally on BMW 524td: warning lights for water in fuel and electronic fuel injection system control; telltales for preheating and start readiness	23

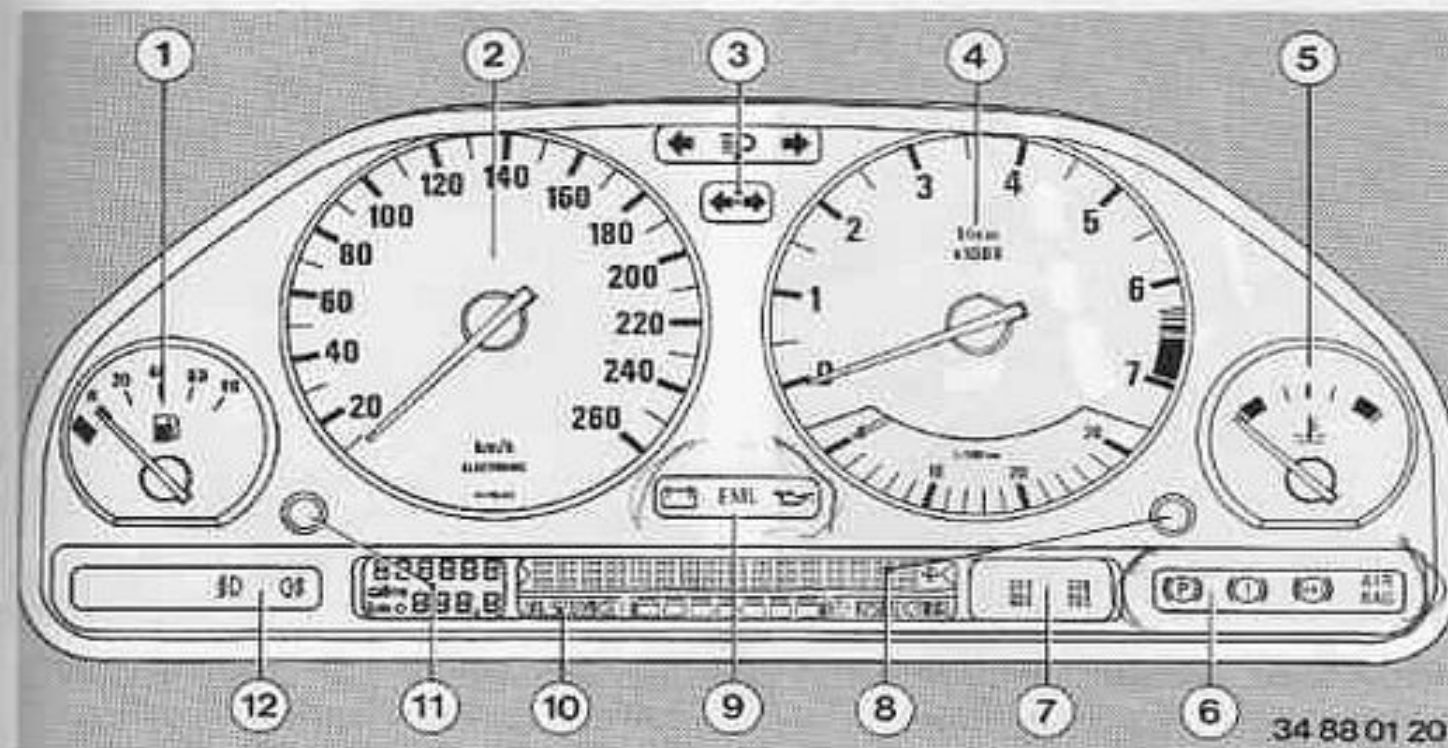

### Instrument cluster

1 - Fuel gauge with telltale	Page
2 - Speedometer	22
3 - Turn indicator, high beam and trailer flasher telltales	23
4 - Revolution counter with Energy Control	21
5 - Coolant temperature gauge	22
6 - Telltale and warning lamps for handbrake, brake hydraulics, antiblock braking system (ABS) and AIRBAG	23, 15
7 - Automatic transmission selector lever position lamps and program display	28
8 - Check Control display and key	24
9 - Battery charge, EML and oil pressure telltales	23
10 - Service Indicator	22
11 - Total and trip distance recorders with reset knob	21
12 - Front and rear fog light telltales	23

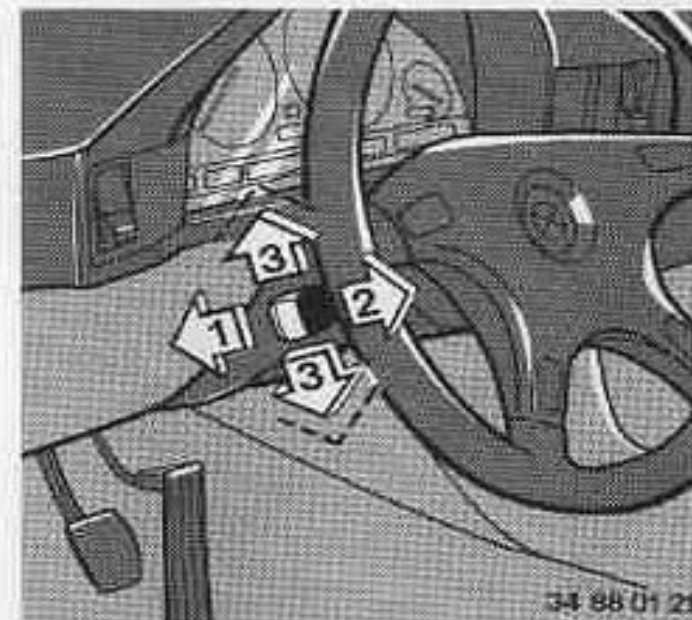

### Turn indicator and high/low beam lever

- 1 - High headlight beam (blue telltale)
- 2 - Headlight flasher
- 3 - Turn indicators (green telltale lamp flashes and the flasher relay emits a ticking sound)

If the telltale lamp flashes faster and the ticking occurs more rapidly than normal, one of the turn indicator bulbs has blown.

When the steering wheel is returned to the straight-ahead position after the turn indicator has been set, the lever will be returned to the off position automatically unless the steering wheel was turned only slightly.

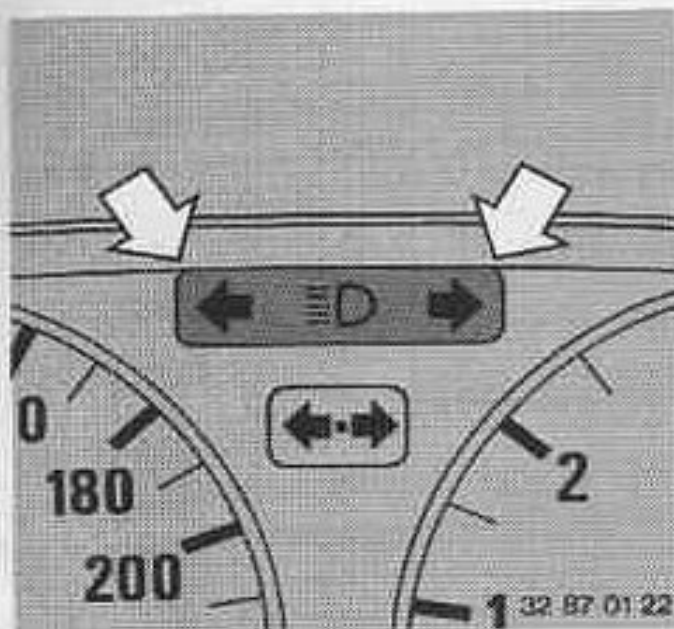

### Brief operation of turn indicators

When pulling away from the roadside or changing lanes, you need only move the lever slightly away from its rest position. When released, it will cancel immediately.

### Parking lights, right or left

Move the turn indicator lever beyond the normal indicating position and allow it to engage.

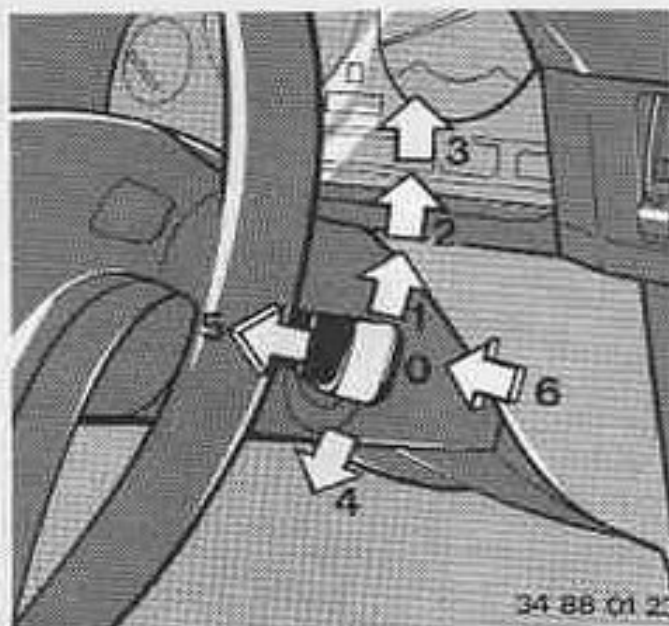

### Wash/wipe system

- 1- Intermittent wipe
- 2- Normal wiper speed
- 3- Fast wiper speed
- 4- Short wipe
- 5- Automatic windscreen wash
- 6- Automatic intensive cleaning

### Headlight and front fog light cleaning

Operate the automatic windscreen wash or intensive cleaning system with the headlights switched on.

Reservoir: see Page 65.

### Position 1 - intermittent action

The interval depends on vehicle speed. If facility for programming is available: Move briefly to position 1 from position 0.

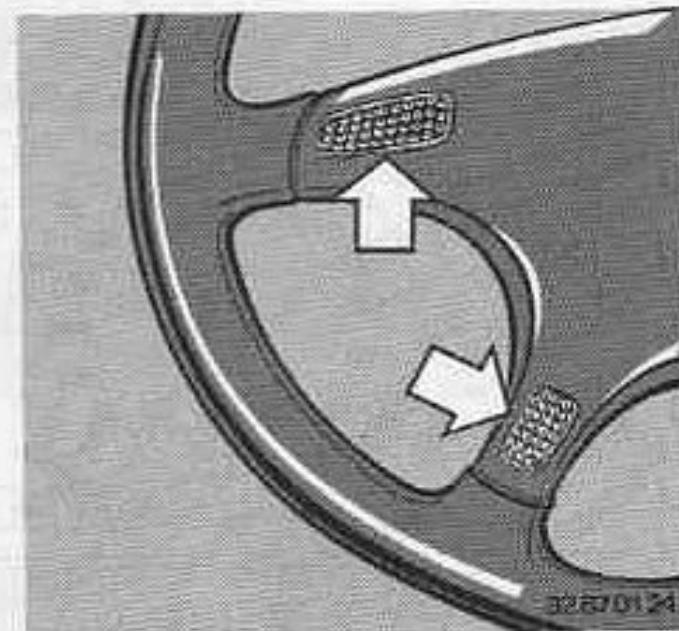

The time before the wipers are again switched on (from position 0 to position 1) is the programmed interval (max. 20 s, twice as long when the car is standing still). To cancel the programmed interval, return the lever to 0.

### Position 2 - normal wiper speed

The wipers operate intermittently when the car is standing still.

**Heated windscreen washer jets:** switched on automatically when ignition key is in position 2.

### Horn

Press one of the horn pushes.

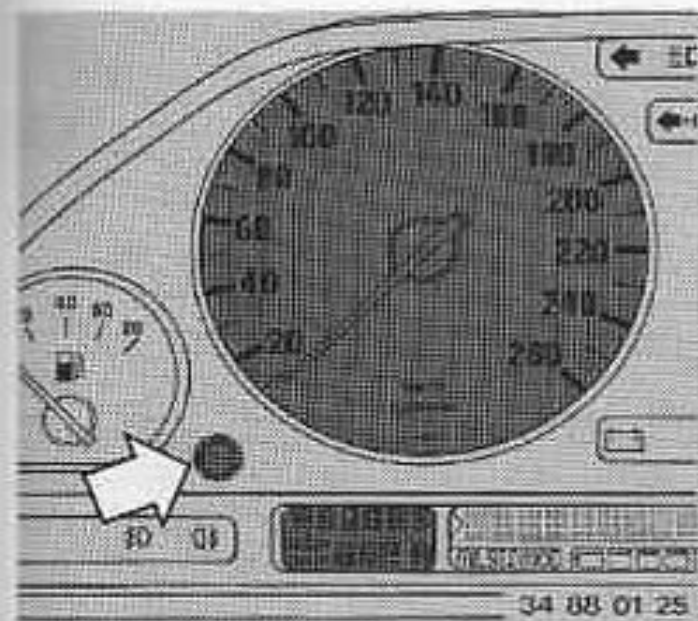

### **Speedometer**

The distance recorder shows the total number of kilometres or miles covered by the car.

### **Trip recorder**

Records journey distances up to 999.9 km or miles.

Press the button to reset to zero.

If the red spot is alight: the coding plug for the trip distance recorder has been renewed.

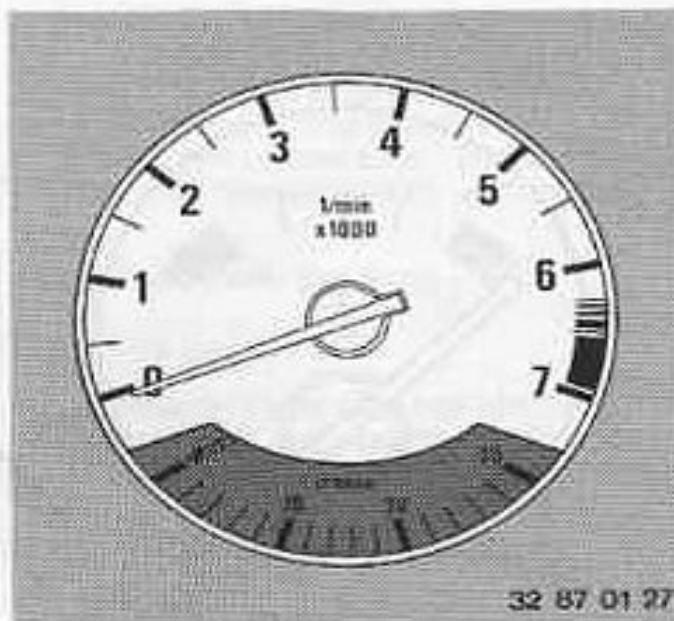

### **Revolution counter**

Avoid engine speeds in the red warning zone.

The fuel combustion process is interrupted in this zone to protect the engine, which runs unevenly as a result.

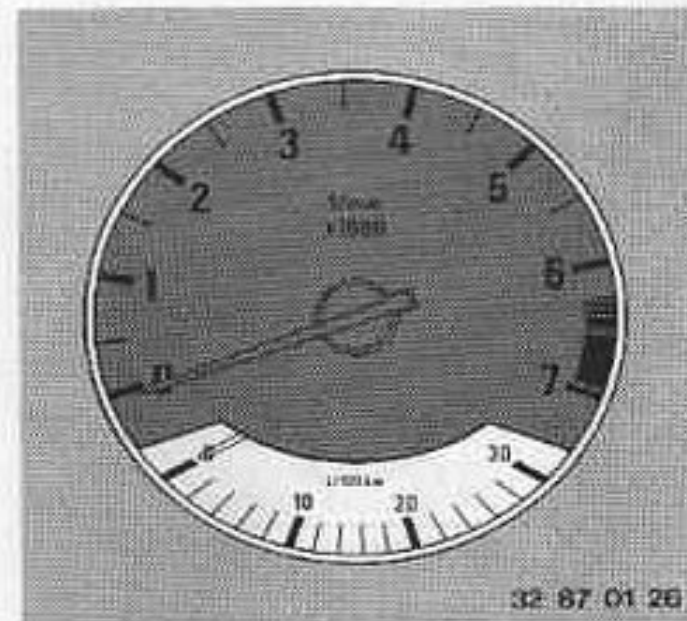

### **Energy Control**

Shows fuel consumption above a speed of app. 20 km/h

The dial clearly indicates whether the car is being driven economically or not.

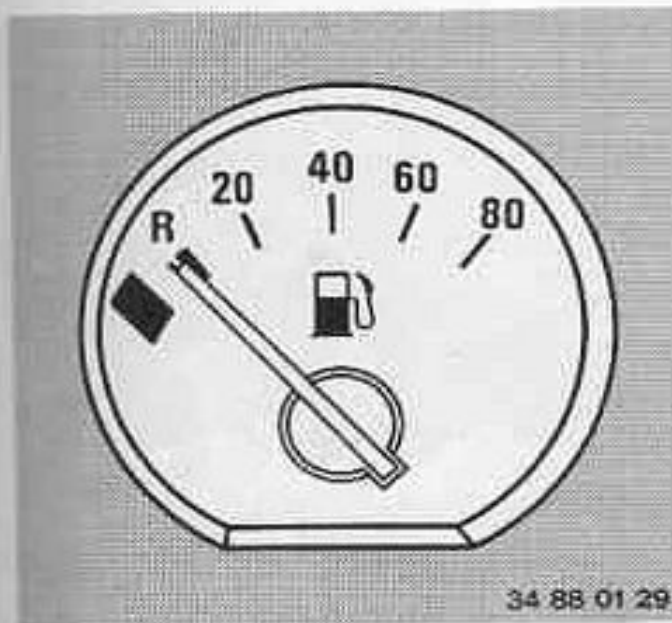

### Fuel gauge

The telltale lamp comes on to indicate that there are app. 8 litres (1.75 imp. gal) of fuel remaining in the tank.

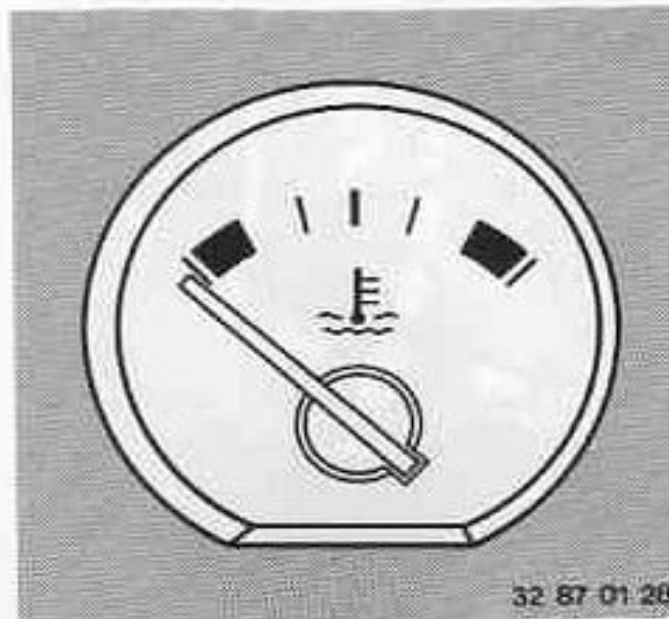

### Coolant temperature gauge

**Blue:** engine cold. Drive at moderate engine and road speeds.

**Red, "COOLANT TEMP" warning (in Check Control):** engine too hot. Stop the engine immediately and allow it to cool down.

Between the two coloured zones: normal operating temperature. If outside temperatures are very high or the engine has been working very hard, the needle may approach the red zone.

Checking coolant level, see page 65.

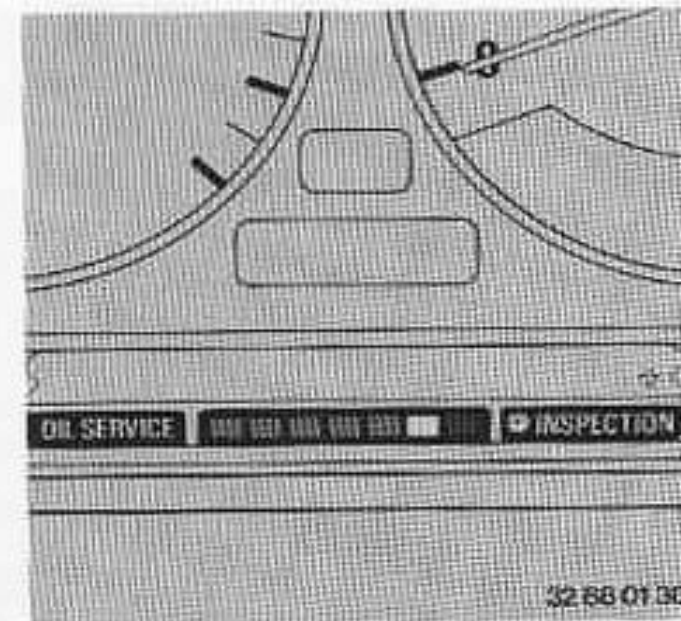

### Service Indicator

**Green light-emitting diodes (LED):** the fewer are on, the sooner the next service will be due.

**Yellow LED** in conjunction with OILSERVICE or INSPECTION: comes on when the next service routine is due.

**Red LED:** a service routine is overdue.

**Clock symbol** in conjunction with INSPECTION: shows that an annual inspection is due.

All displays go out when the engine is started.

Cars without Check Control: the appropriate display and the yellow or red LED remain on during travel.

The Service Indicator is reset by the BMW service station after the appropriate work has been performed.

For further notes, see the Service Booklet.

## Telltale and warning lamps

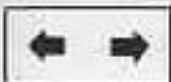

### Left/right flashing turn indicators

Flashes in the same rhythm as the turn indicators when these are being operated.



### High headlight beam

Comes on when the high-beam headlights are on and when the headlight flasher is operated.



### Trailer turn indicators

Operates together with the vehicle turn indicator telltale when towing a trailer.

For further notes see Page 88.



### Brake lining wear

Goes out after the engine has started.

If the lamp comes on during a journey, renew the brake linings immediately.

**Warning:** only use brake linings approved by BMW, as the General Operating Permit will otherwise be invalidated.



### Handbrake

Goes out after the engine has started.

Comes on when the handbrake is applied.



### Brake hydraulics

Goes out after the engine has started.

If the lamp comes on during a journey, brake fluid level is too low.

For further notes see Pages 64 and 72.



### Antilock braking system (ABS)

Goes out after the engine has started. If the lamp comes on during a journey, the ABS is faulty and out of operation. The brakes can be operated conventionally, with no loss of effect.

For further notes see Page 90.



### Oil pressure

Goes out after the engine has started. It may come on when the engine is idling if hot, but must then go out as engine speed increases.

If the lamp comes on during a journey and the ENGINE OIL PRESS display is shown by the Check Control, stop the car immediately and switch off the engine. Check the oil level and add more oil if necessary. If the oil level is correct, consult a BMW service station.



### Electronic engine output control

Comes on briefly when the ignition is switched on, then goes out if the system is operational.

If the lamp remains on or comes on again during a journey, there is a system malfunction.

Consult a BMW service station. It may be possible to continue the journey at a low engine speed.



### Battery charge

Goes out after the engine has started.

If the lamp comes on during a journey, there is a fault at the alternator V-belt or in the charging circuit so that the battery is not being charged.

## Warning:

If the V-belt is faulty, the coolant pump is no longer being driven and there is a risk of the engine overheating.

Consult a BMW service station.



### Front fog lights

Comes on when the front fog lights are switched on.



### Rear fog light

Comes on when the rear fog lights are switched on.

## BMW 524td



### Start readiness

For further notes, see Pages 54 and 73.



### Preheating

For further notes, see Pages 54 and 73.



### Water in fuel

For further notes, see Page 73.



### Electronic fuel injection system control

For further notes, see Page 73.

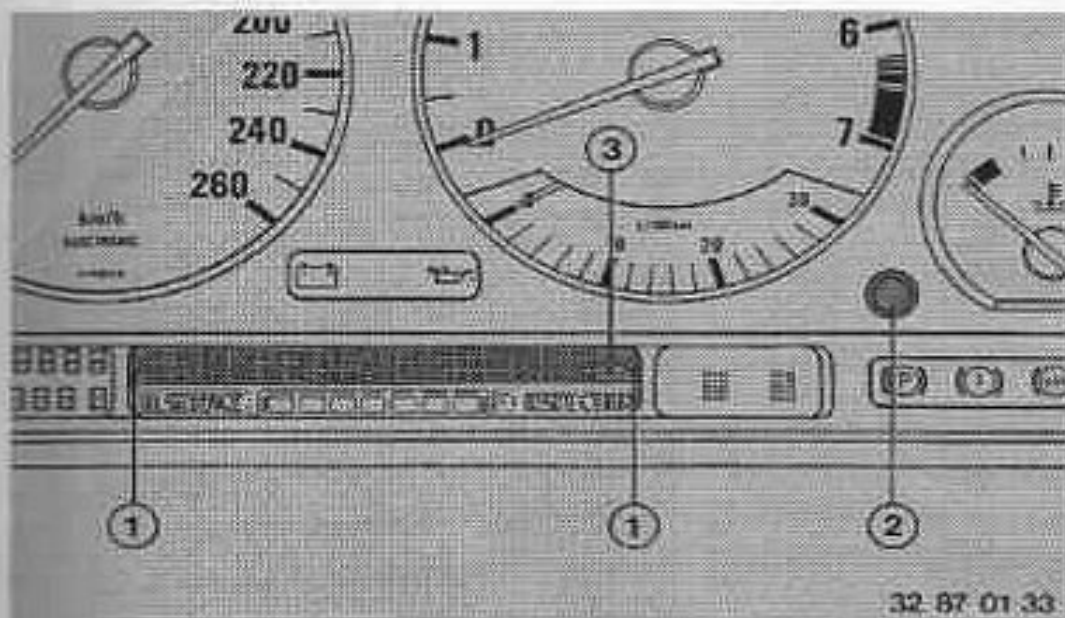

### Check-Control

The following system faults are displayed in the form of inscriptions, and a gong warning is sounded.

A distinction is made between three levels of priority.

#### Priority 1

##### Display

■■■■ ASC ■■■■

LOW BRAKE FLUID

ENGINE OIL PRESS

COOLANT TEMP

HANDBRAKE ON

BRAKE CIRCUIT

##### Instruction/remedy

ASC in operation (gong does not sound) – see Page 35

Level fallen to MIN/top up at next opportunity, see Pages 64, 72

Too low/stop car and switch off engine at once. See Pages 23, 62

Coolant temperature too high/stop car and switch off engine at once. See Pages 21, 65

Displayed after a minimum road speed has been exceeded

Brake light failure – fuse blown or circuit fault/renew fuse (See Page 67) or consult BMW service station.

The above faults are displayed immediately, accompanied by a warning gong and flashing warning symbol (1). If more than one fault occurs at once, the displays are shown in succession. These displays cannot be cancelled with the Check Control (CC) key (2).

#### Priority 2

##### Display

TRANS PROGRAM

BRAKE LININGS

ASC DEFECTIVE

1 BRAKE LIGHT

DIP BEAM

TAIL LIGHT

LIC. PLATE LIGHT

TRAILER LIGHT

##### Instruction/remedy

Automatic transmission: defect in shift electronics/see Page 29

Worn/see Page 72

System fault/see Page 35

Bulb blown/see Page 76

Bulb blown, fuse blown or circuit defective/see Pages 75 or 67, or consult BMW service station

Trailer lighting fuse blown or circuit failure/renew fuse or consult BMW service station

The displays appear when the ignition key is in position 2 (if priority 1 faults occur, these are automatically superimposed). After the display has gone out, the reminder symbol remains. If a plus sign (3) appears, this means that there are further displays which should be called up by pressing the CC key.

**Note:** With the CC key, displays can be cancelled before automatic cancelling takes place, and other stored displays shown by symbols can be called up.

**Priority 3**

Display	Instruction/remedy
ENGINE OIL LOW	Engine oil level has dropped to MIN/ check oil level and top up to next opportunity (when re-fuelling)/see Page 62
COOLANT LEVEL	Coolant is too low/top up at next opportunity, see Page 65
WASHER FLUID LOW	Windscreen washer fluid level has dropped/ see Page 65
OIL PRESS SENSOR	Sensor for engine oil pressure faulty/consult BMW service station at the next opportunity. Important: low oil pressure is not indicated until this fault is rectified!
OIL LEVEL SENSOR	Sensor for engine oil pressure faulty/consult BMW service station at the next opportunity. Important: low oil pressure is not indicated until this fault is rectified!
CHECK CONTROL	Electronics defect, various announcements cannot be indicated and/or incorrect announcements may be made/consult BMW service station at the next opportunity

The displays primarily appear at the end of the journey, when the ignition key has been turned back to position 0; several displays may appear in succession. Even after removing the ignition key, when the display has gone out, the information can be called up again with the CC key for about another 2 minutes.

Displays also appear before the journey starts, when the ignition key is turned to position 2; they disappear after a short time or when the journey is started, and no reminder symbols remain. A repeat display appears only when the ignition is returned to position 0.

If a plus sign appears: call up further displays by pressing the CC key.

**General information:**

If the OWNER'S HANDBOOK display appears, refer to the car's Owner's Handbook for further information.

Checking operation of the Check Control display:

Turn the Ignition to position 2 – no fault should be displayed. Press the CC key: a dot frame should appear.

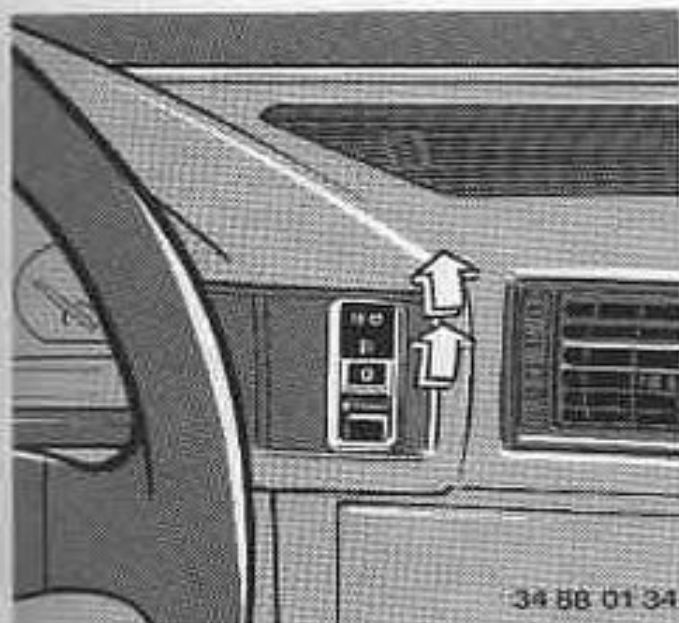

### **Front fog lights**

The green telltale lamp in the instrument cluster comes on when the front fog lights are switched on.

### **Rear fog lights**

The yellow telltale lamp in the instrument cluster comes on when the rear fog lights are switched on.

Please note national regulations with regard to the use of fog lights. In the Federal Republic of Germany, a total of only 4 headlights may be switched on together at any time. For this reason, the front fog lights can only be switched on in conjunction with the parking lights or dipped-beam headlights.

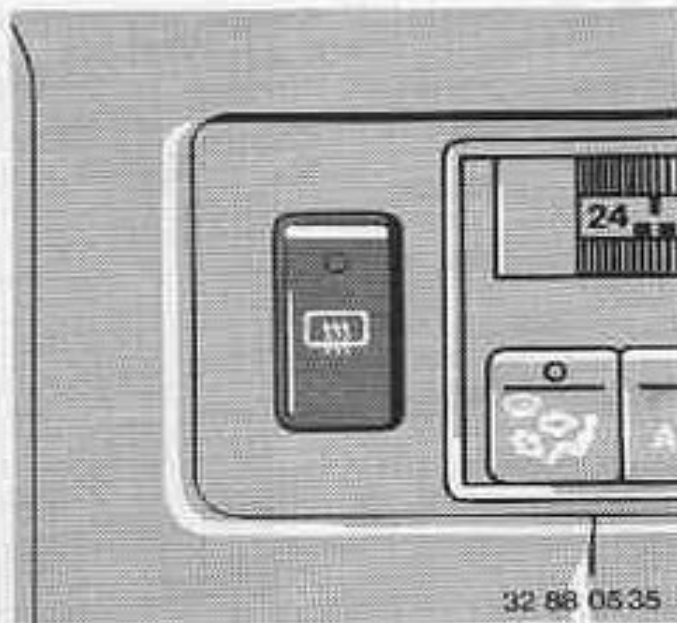

### **Heated rear window**

Press the button: the heating circuit runs at its full output rating when the telltale lamp is on (for rapid defrosting).

When the lamp goes out, the circuit has switched over to the economy rating.

If necessary, press the button again to obtain rapid defrosting for a further short period.

To switch off, press the button again when the lamp is on.

Every time the engine is restarted, the rear window heating has to be switched on again as required.

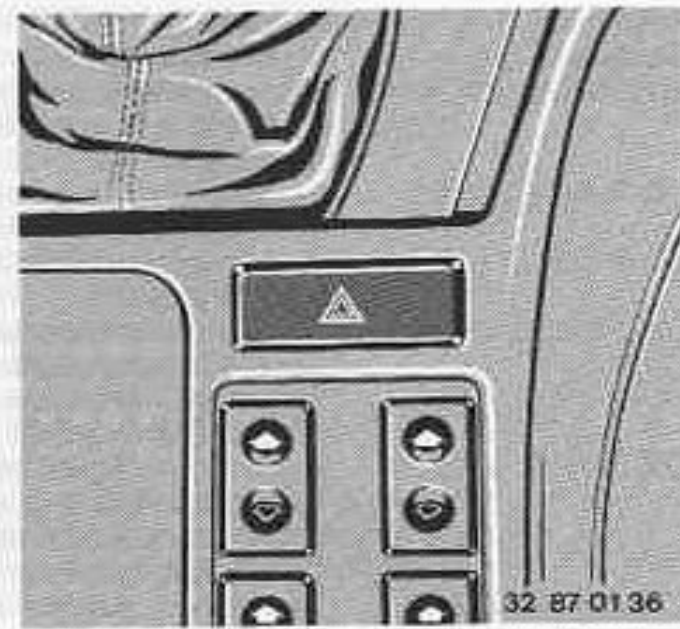

### **Hazard warning flashers:**

The red telltale lamp in the pushbutton with the triangle symbol flashes rhythmically when the hazard warning flashers are switched on.

When the car's lights are switched on, a locating bulb comes on in the pushbutton for the hazard warning flashers.

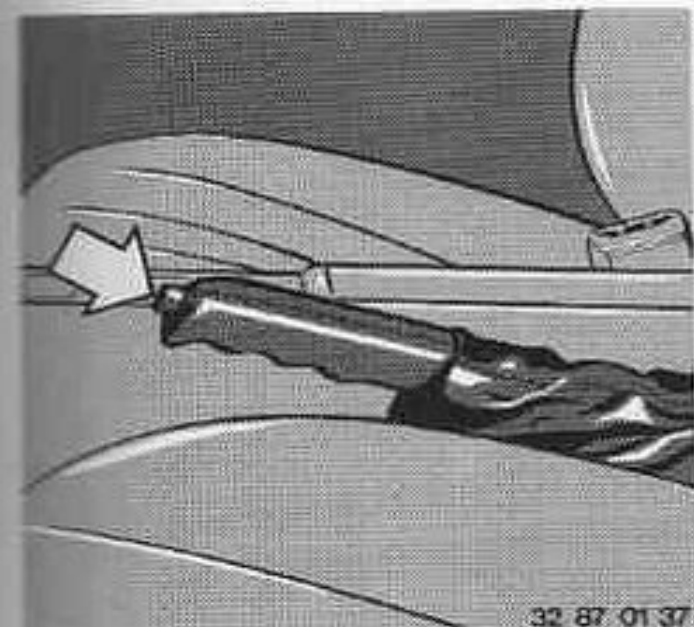

32 87 01 37

### Handbrake

The handbrake engages automatically when pulled up, and the "P" telltale lamp in the instrument cluster comes on.

To release the handbrake, pull the lever up slightly, press in the knob and push the lever fully down.

The handbrake acts on the rear wheels.

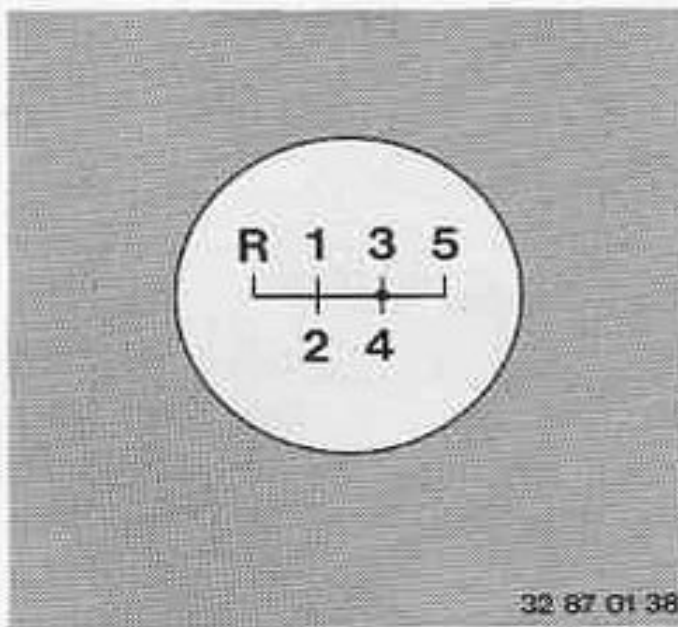

32 87 01 38

### Manual gearbox

The rest position for the gear lever is in the 3rd/4th gear plane. When the lever is moved out of gear, it springs automatically to the rest (neutral) position.

All ratios are equipped with synchromesh.

#### Selecting reverse

With the car standing still, press the gear lever to the left until the slight resistance is overcome.

#### Reversing lights

These come on when reverse gear is selected and the ignition is switched on.

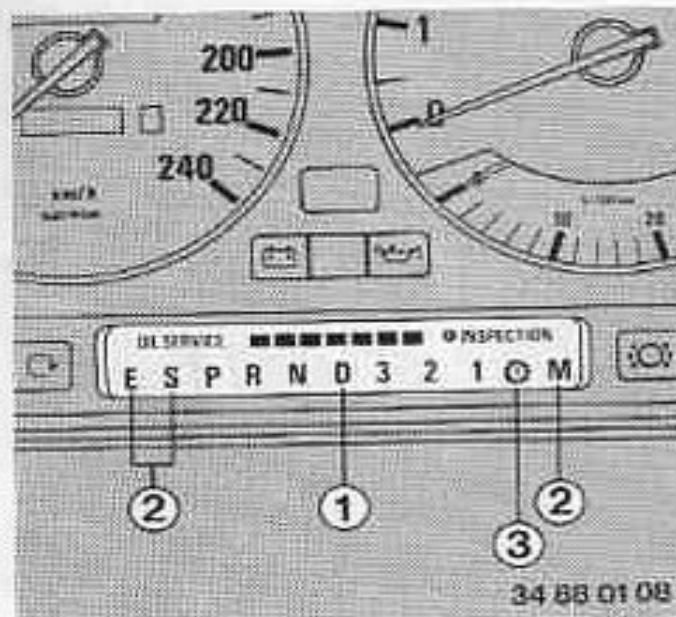

### Automatic transmission

Selector lever position (1):

P R N D 3 2 1

### Electronic-hydraulic transmission

In addition, 3 different shift programs (2) can be selected at the program switch:

E (Economy) – press switch  
 S (Sports) – push switch in  
 M (Manual) – desired direction

### Please note:

The engine can be started in position P or N only

Press the release catch under the selector lever handle as necessary.

After selecting a speed range, wait for the transmission to engage (you will notice a very slight jerk) before accelerating.

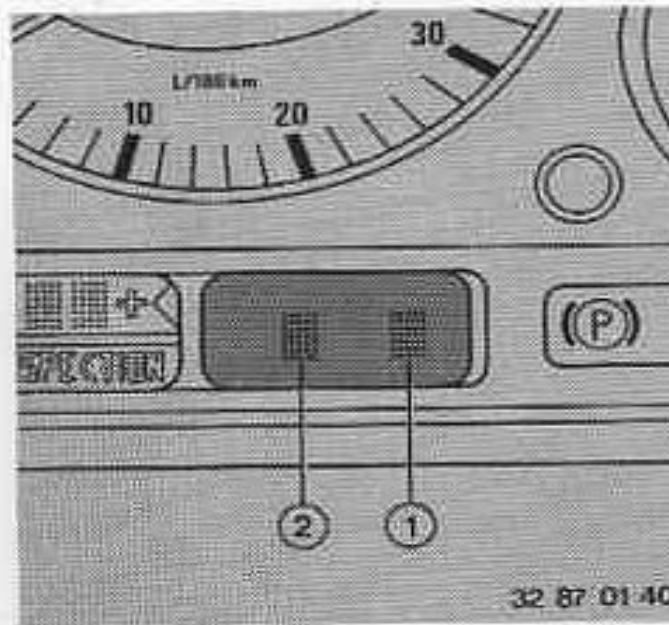

The car tends to creep forwards (or backwards) if the engine is running at idle speed and a drive ratio is engaged.

If you shift accidentally from a drive ratio to N, always take your foot off the accelerator pedal immediately and then select the desired ratio.

Before leaving the car with the engine running, first select P or N and engage the handbrake.

### P – Park

Select only when the car is standing still. The rear wheels are locked to prevent the car rolling away.

### R – Reverse

Select only when the car is standing still and the engine is idling.

### N – Neutral (idling)

Select only when the car is stopped with the engine running for any length of time.

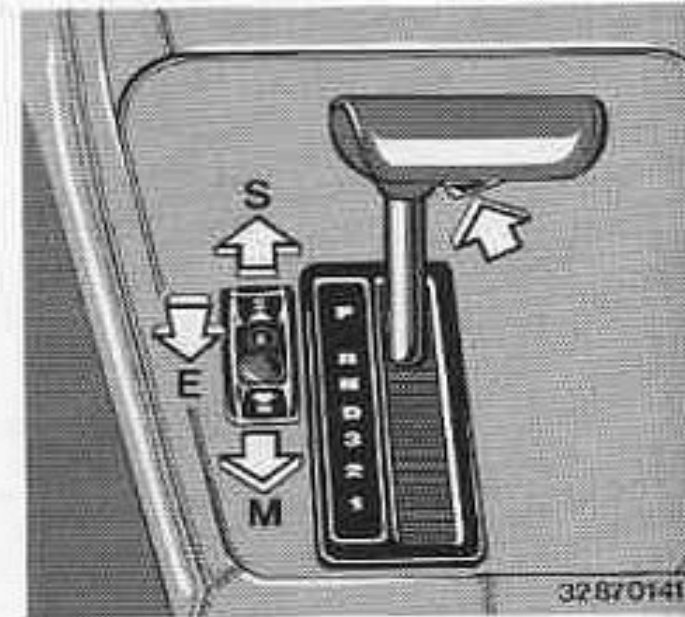

When the car is moving, select N only to counteract skidding.

### D – Drive (automatic)

The normal driving position with automatic transmission.

### 3 – Direct drive

Select this position if road or traffic conditions cause the transmission to hunt between 3rd and 4th when in position 'D'. Only gears 1 to 3 are used.

Never select position 3 above a road speed of 200 km/h.

### 2 and 1 – Hill climbing and engine braking

Select these positions on mountain roads and very long uphill and downhill gradients. They make better use of the engine's performance and braking action, and prevent unnecessary up-shifts.

Positions 2 and 1 can be selected at any speed. However, the transmission will not shift down until a suitably low speed is reached.

Once 2 or 1 has been selected, the transmission will not shift up to a higher gear even if the engine overspeeds as a result.

#### **Kickdown**

The accelerator pedal can be depressed beyond the full-throttle position by overcoming a detent.

Up to a certain speed range, the next-lower ratio is selected to provide improved acceleration. The next upward shift does not take place until a much higher engine speed has been reached.

For towing away, low-starting and starting with a flat battery see Page 64.

## **Electronic-hydraulic transmission**

### **E – Economy program**

After starting the car, select this program for low-consumption motoring.

### **S – Sports program**

This is the program for an enthusiastic driving style. Upward gear shifts are delayed to make fuller use of the engine's power output.

### **M – Manual-shift program**

This program is for single-gear driving (3rd gear if D is selected). The selected gear is also used for pulling away. For example, if the selector lever is in position 1, for tackling steep gradients or when towing a trailer, no undesirable upward shifts will take place. The same applies to driving on icy roads in winter; with the selector lever in position 3, you can pull away smoothly and no gear shifts will occur.

### **Telltale for selector electronics (3)**

Goes out when the engine is started.

If it does not go out or if it lights up during a journey, or if the **TRANS PROGRAM** display appears in the Check Control, there is a fault in the electronic shift system.

All selector lever positions remain available for use, but in positions D, 3, 2 and 1 the transmission will select 3rd gear.

In this event, avoid extreme engine loads and consult the nearest BMW service station.

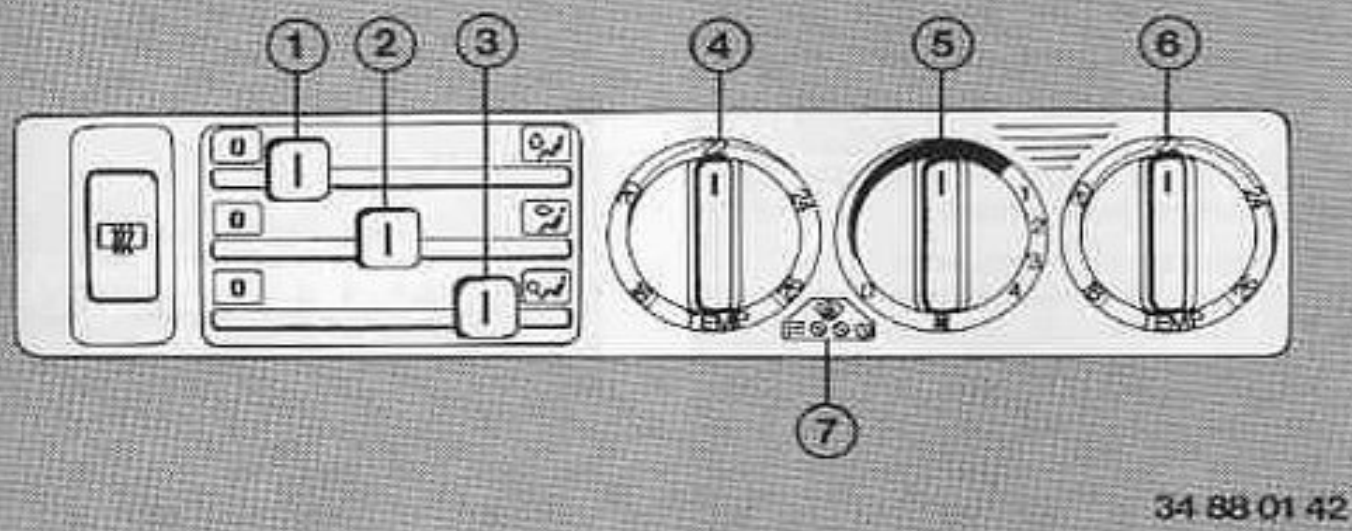

34 88 01 42

**1 - Slide control for upper air distribution**  
**3 - Slide control for lower air distribution**  
 The desired distribution of heated air can be steplessly adjusted.

Slide control at left: closed  
 Slide control at right: fully open

Always keep slide control 3 at least half open, except when defrosting the windscreen, so that the temperature sensor of the electronic heating control remains operational.

**4, 6 - Rotary temperature selectors for driver's/passenger's side**

The calibrations are intended as an approximate guide to the temperature inside the car. The selected temperature is reached as soon as possible after the car has been started, and does not normally need to be altered (electronic heating control).

Alter the setting only by a small amount at a time, to prevent excessive temperature fluctuations.

At the right-hand limit position of the driver's side control, the temperature is no longer regulated automatically on either side (maximum heating setting; also emergency heating position if a fault has developed in the electronic heating control system).

### Heating and ventilation

- 1 - Slide control for upper air distribution
- 2 - Slide control for fresh air distribution
- 3 - Slide control for lower air distribution
- 4 - Rotary temperature selector, driver's side
- 5 - Rotary airflow volume control
- 6 - Rotary temperature selector, passenger's side
- 7 - Settings for maximum windscreen and side window defrosting

### Pushbutton for heated air distribution (slide controls 1 and 3)

Air emerges through the defroster outlets for the windscreen and the front side windows, and via the front and rear footwell outlets.

### Pushbutton for centre air distribution (slide control 2)

Air emerges through the directionally adjustable, controlled-flow grilles in the front of the facia and the controlled-flow grille on top of the facia.

The rear can be ventilated independently via the directionally adjustable, controlled-flow grilles in the end of the centre console.

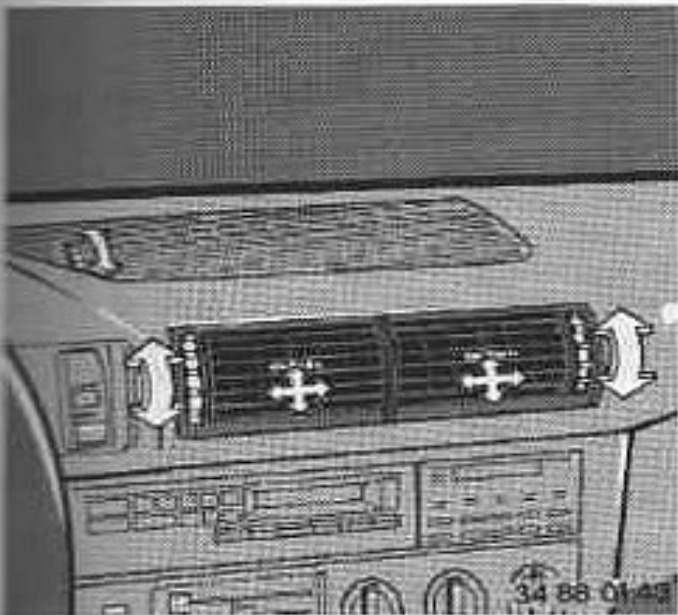

## 2 - Slide control for fresh air inlet

Slide control at left: closed  
Slide control at right: fully open

In addition, every grille can be adjusted individually and the airflow amount regulated by the knurled wheel. The grille on the top of the instrument panel is permanently set to indirect ventilation of the centre area.

The rear can be ventilated independently of the position of slide control 2.

In conjunction with the footwell heating, the ideal stratification for fatigue-free driving of warm feet/cool head can be obtained.

## 5 - Rotary airflow volume control Position 0 : system switched off, air entry shut off.

Turned clockwise to detent: minimum airflow and blower rating.

Turned further to right: airflow volume increases, minimum blower rating.

Higher blower ratings: stages 1 to 4.

For correct operation of the electronic heating control system, the rotary control should always be turned to at least the 12 o'clock position.

For most rapid windscreen and side-window defrosting:

## 7 - Setting for maximum windscreen and side window defrosting

Maximum defrosting effect is not obtained until the engine reaches its normal operating temperature.

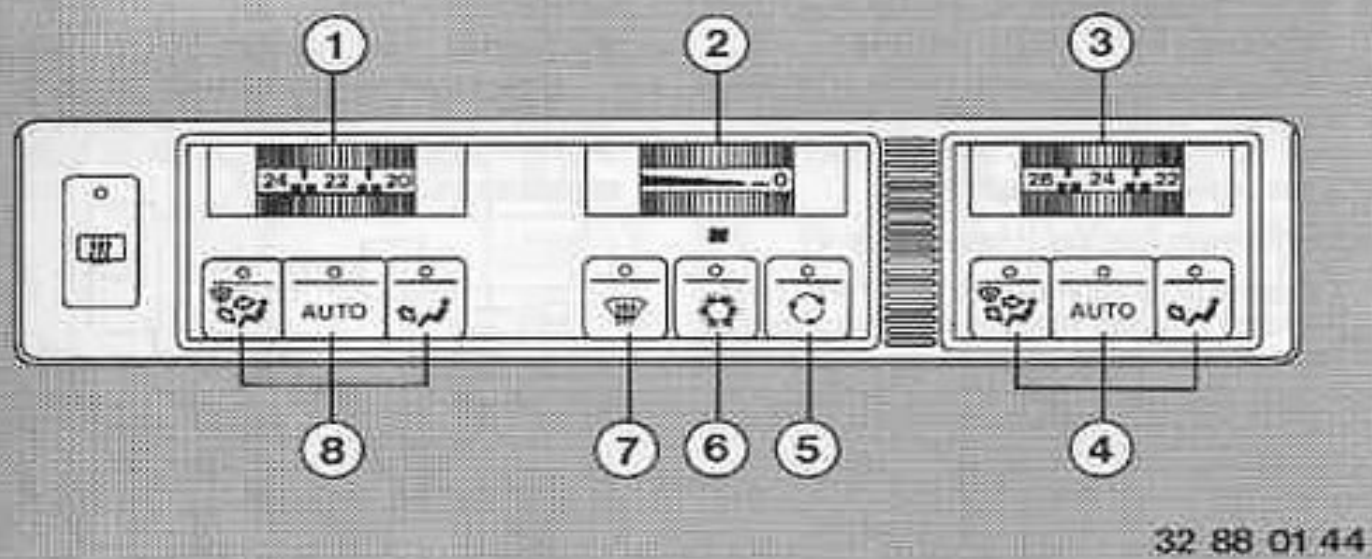

32 88 01 44

### Air conditioning

- 1 - Temperature selector wheel, left side
- 2 - Airflow volume control
- 3 - Temperature selector wheel, right side
- 4 - Right side air distribution program keys
- 5 - Pushbutton for recirculated-air operation
- 6 - Pushbutton for air conditioning
- 7 - Pushbutton for maximum windscreen and side window defrosting
- 8 - Left side air distribution program keys

When a pushbutton is pressed, the corresponding LED lights up.

### 1, 3 - Driver's/passenger's side temperature selector wheel

The calibrations are intended as an approximate guide to the temperature inside the car. The selected temperature is reached as soon as possible after the car has been started, and does not normally need to be altered. Alter the setting only by a small amount at a time, to prevent excessive temperature fluctuations.

At the two extreme limit positions of the driver's-side control, the temperature is no longer regulated automatically on either side. In case of a defect in the electronic heater control this position can provide an emergency circuit.

### 2 - Airflow volume control

**Position 0:** system switched off, air entry shut off.

Turned clockwise to detent: minimum blower rating.

Turned further to right: airflow volume increases.

### 4, 8 - Passenger's/driver's side air distribution program keys

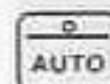

**Air distribution takes place automatically in accordance with the temperature situation.**

Air outlets: through the defroster outlets to the windscreen and front side windows, through the directionally controllable, variable-flow grilles on the facia and the variable-flow grille on the top of the facia, the front footwell outlets and the outlets for the rear passenger area and through the directionally controllable, variable-flow rear-seat ventilation grilles at the rear end of the centre console.

After a cold start in cold weather and until the heater matrix has reached 30°C, air emerges from the defroster outlets only.

**This program is suitable for all normal conditions with very few exceptions, and supplies air to the interior at a pleasant and acceptable temperature.**

For optimum operation of the automatic air distribution system, the facia grilles must not all be closed at the same time.



**Air supply to all outlets and grilles, without automatic air distribution control.**

This program is recommended for warmer weather in particular, when special ventilation or cooling of the lower part of the car's interior is required.

**Note:** if the windscreen and side windows mist over during a journey and you do not wish to press button 7:

Press this button, increase the airflow if necessary and close up the ventilation outlets.



### Air distribution to front and rear footwell outlets only.

The defroster outlets are only slightly open, and no air reaches the grilles at the rear end of the centre console.

This program is recommended in cooler weather, for example when no fresh-air ventilation is required or to warm up the footwell area quickly.



### 5 - Pushbutton for recirculated-air operation

Recommended when driving through badly contaminated outside air. The air inside the car is recirculated and no outside air permitted to enter.

Although the air conditioning is automatically switched on to improve the quality of the air by removing excess moisture, the recirculated-air setting should not be used for too long at a time.



### 6 - Pushbutton for air conditioning

The air conditioning is switched on in all programs at an outside temperature of approx. +1°C and above.

If maximum cooling performance is needed, the system switches automatically to recirculated-air operation (with a small proportion of additional fresh air), and the defroster outlets are closed.



### 7 - Pushbutton for maximum windscreen and side window defrosting

When this button is pressed, maximum windscreen and side window defrosting is selected automatically, with no additional control movements needed.

Maximum defrosting effect is not obtained until the engine reaches its normal operating temperature.

When this button is released, the previous control settings are automatically restored.

**Note:** when this button is pressed, rear window heating is also in operation.

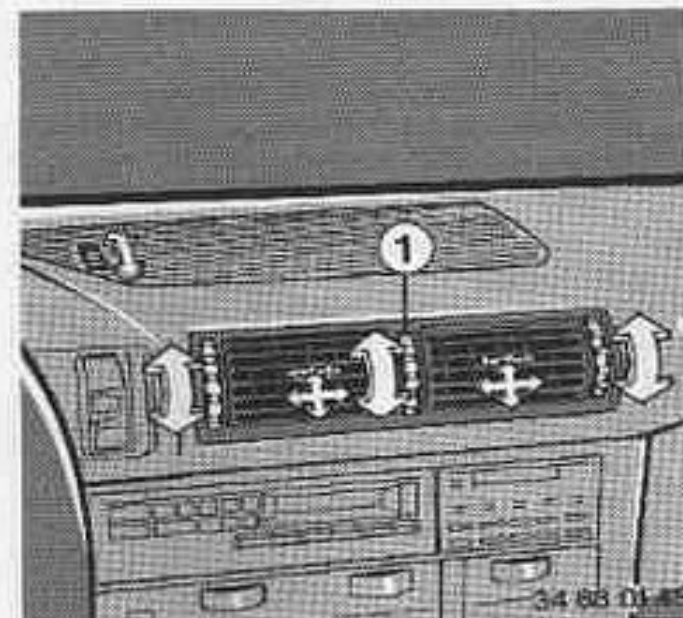

**Stratified temperatures for freedom from fatigue on long journeys: feet warm, head cool**

**Driver and front passenger:** knurled wheel 1 varies the temperature of the air emerging from all facia grilles (except when maximum cooling performance has been selected).

Up: warmer  
Down: cooler

**Rear-seat passengers:** open and alter the direction of the grilles at the rear end of the centre console as required. These grilles supply fresh air only (cooled air if the air conditioning is in operation).

**Important:** the rotary temperature selectors vary the temperature at all air outlets, apart from the grilles at the rear end of the centre console (fresh or cooled air only).

Rear-seat area ventilation is shut off automatically in the driver's-side programs

- AUTO - (cold weather only) and
- air distribution to footwell outlets only.

**Important notes on air conditioning operation**

- 1. The moisture condensate which forms at the evaporator is discharged underneath the car. Depending on humidity, up to 2 litres of water may be discharged per hour.
- 2. The air conditioning must be run briefly at least once a month to prevent the compressor shaft seals from drying out and allowing refrigerant to escape. This is particularly important during the winter.
- 3. If any malfunction occurs in the air conditioning system, for instance no cold air output after switching on, it must be switched off immediately and taken to a BMW service station equipped for air conditioning repairs.

Addresses of BMW service stations able to repair air conditioning systems are given in the "BMW Service" booklet.

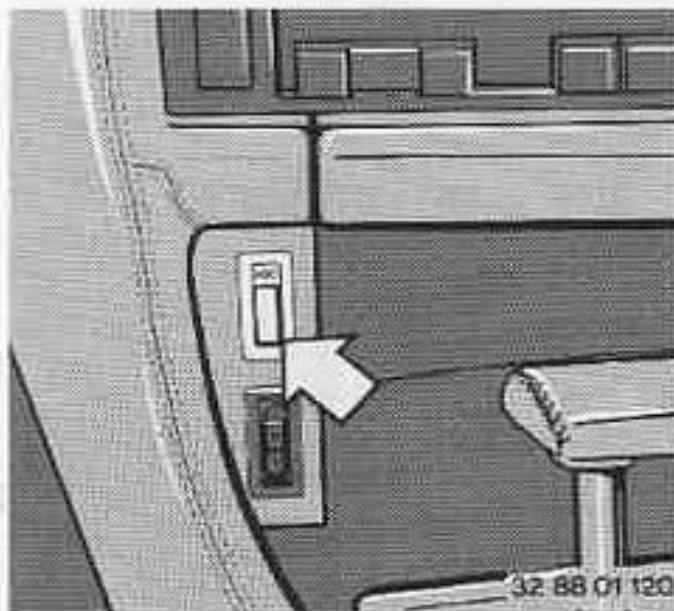
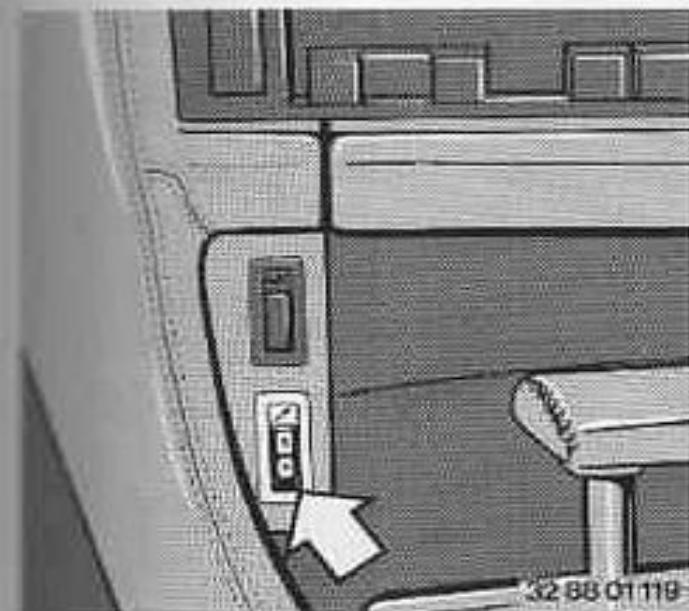

### **Adjustable shock absorbers** (in preparation)

- K - 'Comfort' setting
- S - 'Sport' setting

The settings can be changed at any time when the ignition key is in position 2 (even if the car is moving).

The chosen setting ('Comfort' or 'Sport') can be retained regardless of speed or load.

The setting in use is illuminated. If a malfunction occurs, the telltale lamp goes out. The car should then be taken to a BMW service station as soon as convenient.

### **ASC - Automatic Stability Control**

This system prevents the driven wheels from spinning even if road conditions are poor (e.g. slippery surfaces), and ensures maximum traction and grip within the limits imposed by the physical laws acting on the car.

**ASC is ready for operation automatically whenever the engine is started** (telltale lamp in switch illuminated).

**If the telltale lamp flashes and the display ■■■ ASC ■■■ appears in the Check Control:**

The ASC system is active, that is to say driving conditions have made it necessary to influence the amount of power transmitted to the rear wheels.

**If the telltale light goes out and the Check Control displays 'ASC DEFECTIVE':**

There is a system malfunction. The car can still be driven normally, but without the protection afforded by ASC. Have the car examined by a BMW service station.

**To switch off the ASC:** press the button; the telltale lamp will go out.

**To re-activate the ASC:** press the button again; when the telltale lamp comes on, ASC is ready for operation.

For further information, see Page 91.

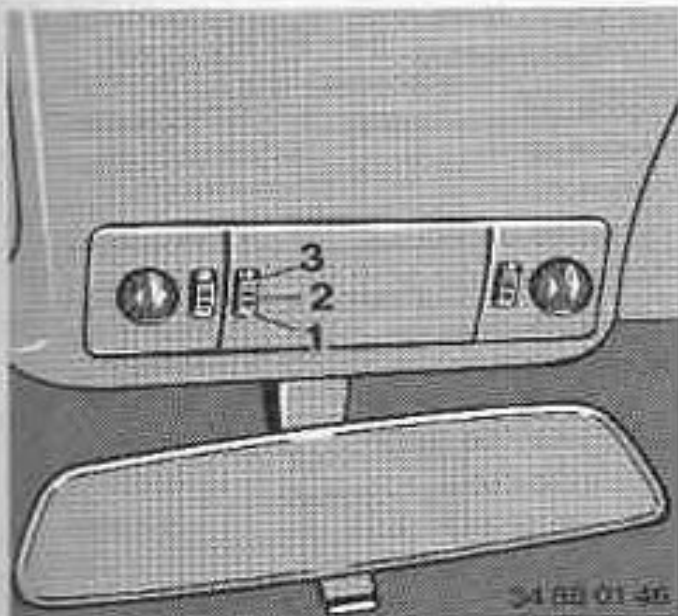

### Interior light

- 1 - Lights on only when a door is open (door contact switches) and after an accident
- 2 - Lights permanently off
- 3 - Lights permanently on

The reading lights next to the front interior light are operated similarly.

### Automatic interior light

Lift up the driver's door handle. The light comes on (max. three times) and goes out again a few seconds after the door is closed or when the ignition is switched on.

If the car's lights were switched on, the interior light goes on when the ignition switch is turned off and is switched off again a few seconds after the doors have been closed.

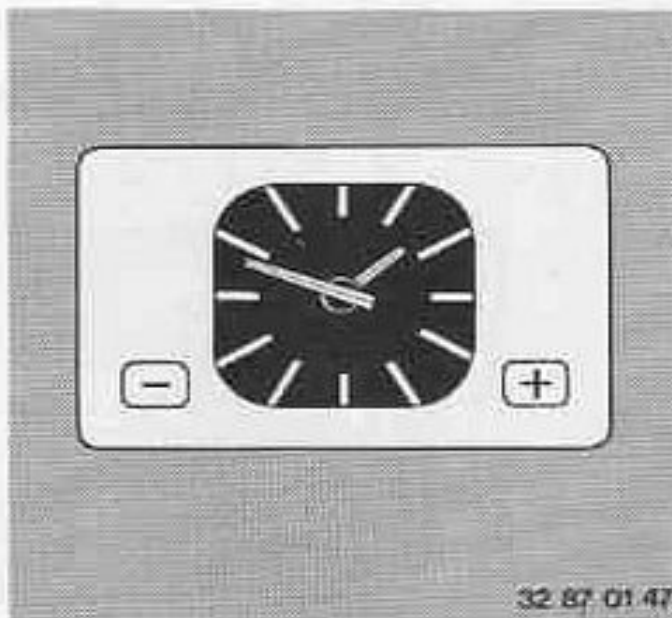

The rear seat reading lights are operated by switches next to them.

### Analog clock

- + key: to move the hands clockwise
- key: to move the hands counter-clockwise

If the key is touched briefly, the minute hand is reset by one minute.

If the key is pressed firmly, adjustment is continuous; the longer the key is pressed, the faster the hands move.

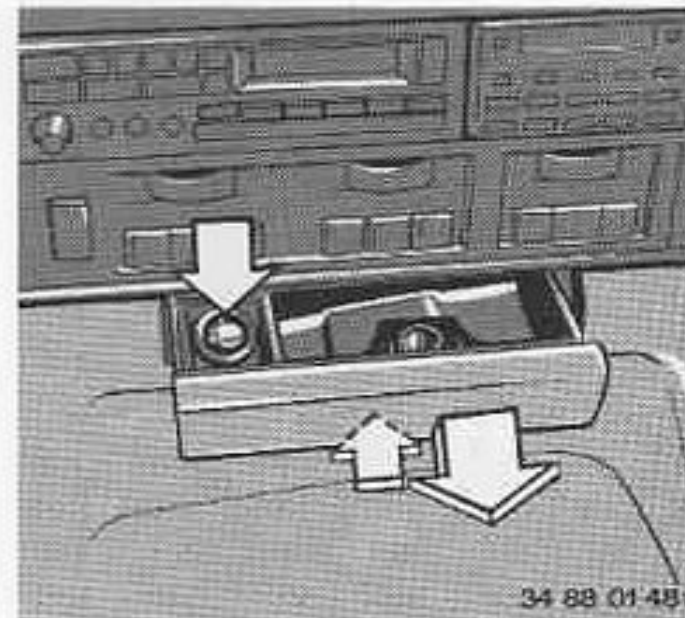

### Cigarette lighter

Press the knob to operate. When the spiral element has heated up, the lighter jumps out to its original position and can be removed.

### Cigarette lighter socket

This can also be used as a power socket for a hand lamp, car vacuum cleaner etc. rated up to app. 12 V, 200 Watt. Be careful not to damage the socket by inserting a plug of the wrong pattern.

### Emptying the front ashtray:

Pull the ashtray fully out. Press the spring under it and lift out the ashtray.

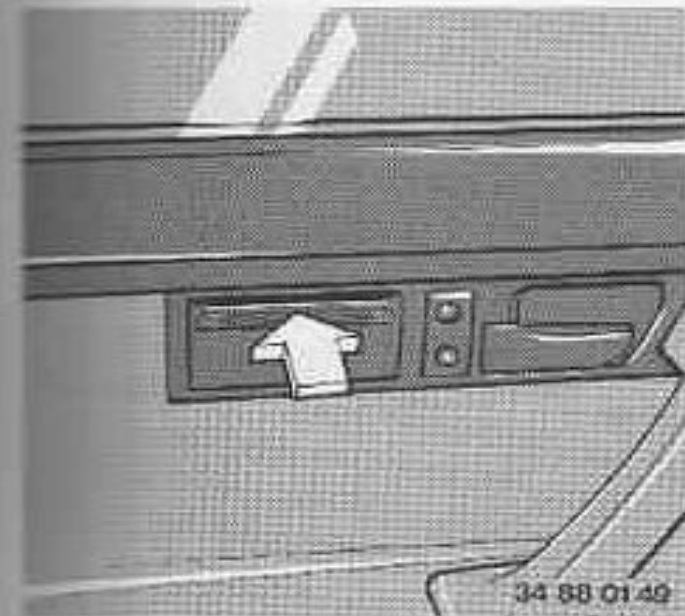

#### Emptying the one-touch rear ashtrays

Tap the ashtray at the top; it opens automatically.

To empty the open ashtray, press down the spring and remove the ashtray. After emptying, re-insert the ashtray and push in to close.

Cigarette lighter for rear passengers: at end of centre console.

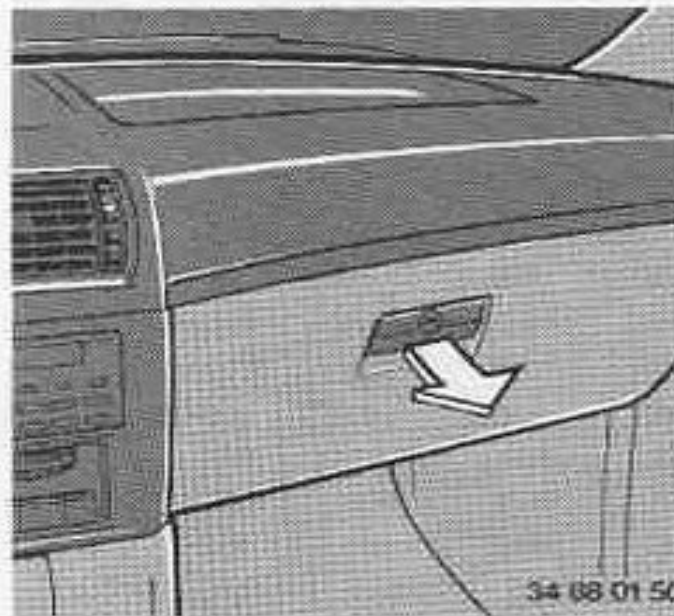

#### Glove box

Open by pulling the handle; the light comes on.

Fold the lid back up to close.

Lock with a master key.

To renew the light bulb (5 Watt), press out the lamp with a screwdriver blade and change the bulb.

#### Rechargeable hand lamp

The lamp is located in the left of the glove box. It has a built-in overload cutout and can therefore remain plugged in all the time, so that it is fully charged whenever needed.

**Warning:** do not plug the lamp in while it is switched on.

#### Other storage compartments:

On the fascia, in the front doors, on the centre console and on certain models the reverse of the front seats.

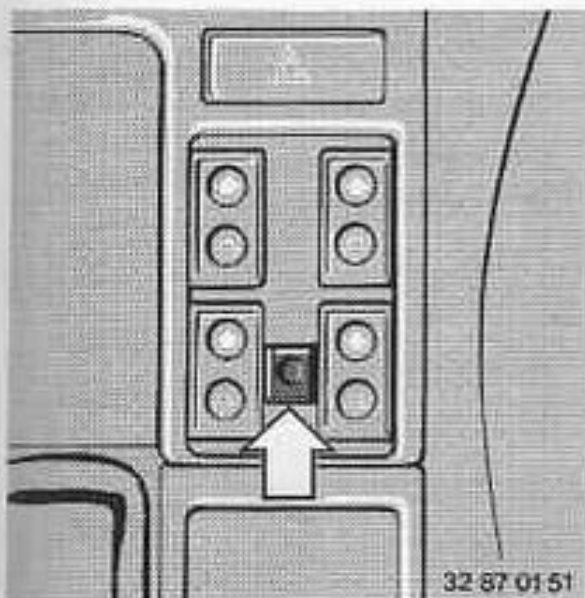

32 87 01 51

### Electric window lifts

To operate, the ignition key must be in position 2.

**Inching function:** the driver's door window can be moved by touching the switch momentarily. A further touch halts window movement.

Individual switches are provided under the rear door windows.

#### Safety switch (arrow)

To prevent operation of the rear windows, e.g. by children.

### Convenience circuit for electric windows and electric sliding/vent roof

After the ignition has been switched off and the key has been removed or is still in position 0, these items of equipment can still be operated (for instance, if you have forgotten to close them) until the front doors have been opened and closed once.

**After the doors have been closed,** insert the door key in the door lock, turn it in the "close" direction and hold it there. This will close the electric windows and sliding roof (convenience circuit).

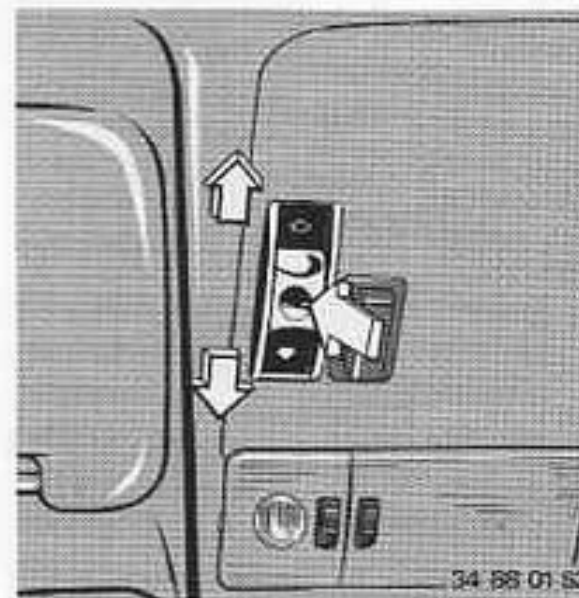

34 58 01 52

### Sliding/vent roof - electric

**Raising:** press the switch.

**Opening:** slide the switch to the rear.

**Closing:** slide the switch forwards.

**Inching function:** to open or close a partly-open sunroof, just operate the switch briefly in the desired direction. A further touch halts the movement.

An electronic circuit breaker protects the system against overloading and similar faults.

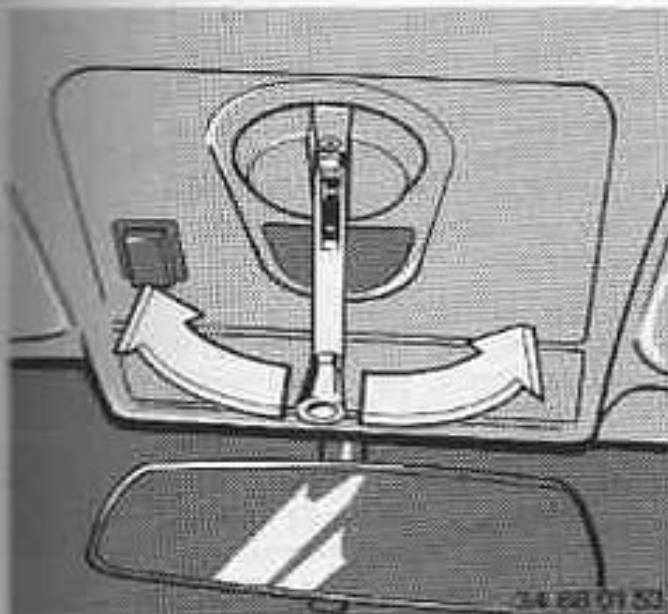

### **Sliding/vent roof – mechanical**

**Opening:** fold out the crank, turn counter-clockwise until pressure point is reached.

**Closing:** turn clockwise, pressure point must be overcome when closing.

**Raising, with roof closed:** turn clockwise (pressure point).

**Lowering:** turn counter-clockwise, pressure point must be overcome when closing.

**Important:** fold the crank handle back into the recess after use.

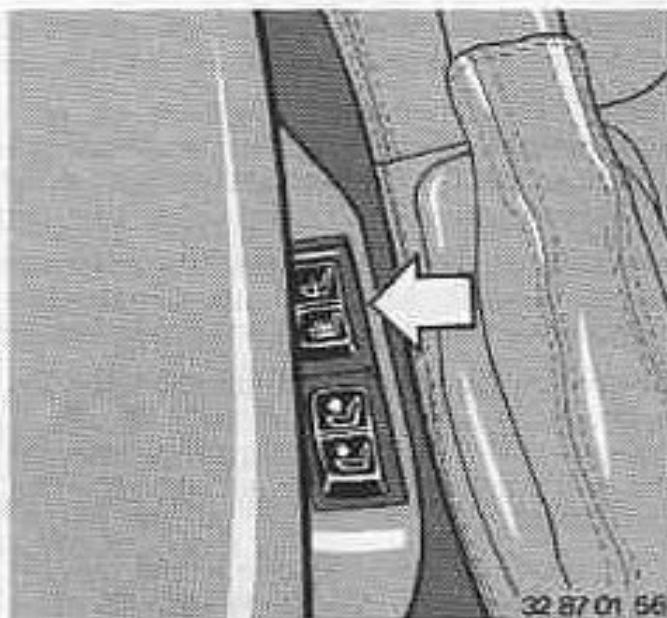

### **Electric seat adjustment**

Press rocker switch with heating symbols:

3 spiral heater elements – for heating up

1 spiral heater element – for keeping warm

**You are recommended** to switch from heating up to keeping warm after app. 5 minutes.

The green tailtale lamp in the switch comes on when the seat heating is on.

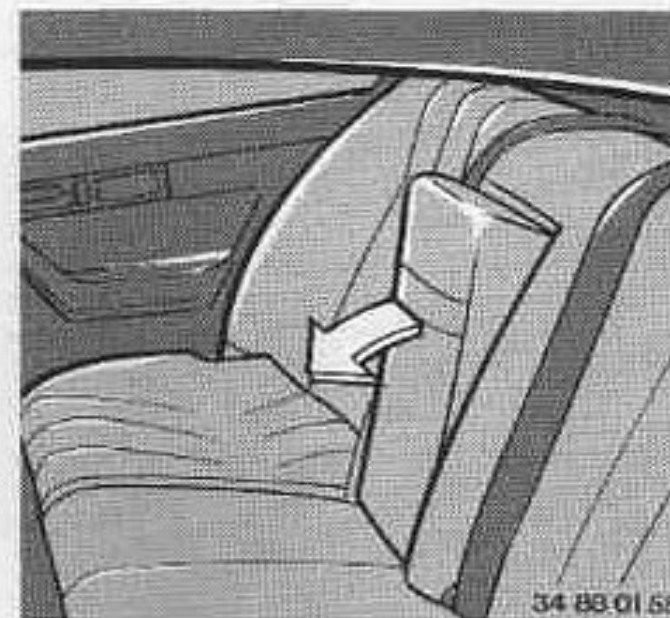

### **Rear centre armrest**

Pull the loop to extend.

### **Front armrests**

To release the catch, press the button on the front.



32 87 01 59

### Outside temperature display and digital clock

In addition to the actual time, the date and the outside temperature can be displayed and the MEMO key used to select an hourly reminder signal.

In ignition key position 0, time and date can be read off after pressing the appropriate function key. In ignition key position 1 and beyond, the time is displayed. Numerical values can be input or modified.

#### Time and date inputs

After the power supply has been interrupted (initial input, flashing dot), the time can be input without first pressing the function key (HOUR) by way of the two input keys h/DAT and min/DAT. To input the date, the DATE function key must first be pressed.

Each time an input key is pressed or held in for half a second, the numerical value increases by one.

The clock function is shown by a symbol, the date function by the DATE display.

To start the clock to the nearest second, press the HOUR key. To start the calendar program, press the DATE key. The dot will then cease to flash.

Before any other input alterations, keep the appropriate function key (HOUR or DATE) pressed until a flashing dot appears between the hours and minutes or between the day and month.

If another function is selected after making an input, the previous input will remain valid.

The program does not accept unrealistic inputs. The date display disregards leap-years and must therefore be corrected manually.

#### Notes for 12-hour clock

The change from AM to PM takes place every 12 hours and is shown in front of the numerical value. To allow for various national versions of the digital clock and outside temperature display, the time and temperature functions can be reset as follows:

24 h and °C  
12 h and °F or  
12 h and °C

on the rear cover of the unit. When changing from 24 h to 12 h, the input keys automatically change their functions from day and month to month and day (US method of writing date).

#### Memo

The MEMO key is used to switch an hourly reminder signal on and off. The signal is heard 15 s before each full hour, and is useful (for instance when listening to a tape cassette) when news broadcasts are due. The letters ME are displayed when the reminder is activated.

#### Outside temperature

By pressing the TEMP key, an outside temperature display can be obtained. If the outside temperature is below +3°C, an ice warning signal is heard if the ignition key is in position 1 and beyond. At the same time the temperature unit (°C/°F) and the dot in the display flash for 10 seconds.

If another function is selected during this period, and the temperature display selected again afterwards, only the visual warning signal is active for the remaining period.

The temperature warning is repeated if the temperature has risen to +6°C at least once before falling again below +3°C.

Do not rely exclusively on the low-temperature warning: ice can still form on bridges and patches of road in shadow even at indicated temperatures above +3°C.

### ***Time switch for independent heater/ventilation system***

This enables the independent heater/ventilation system to be switched on and off directly, and a switch-on time between 0.00 and 23.59 to be preselected.

**Direct switch-on:** press the ON key for 3 seconds, until the LED flashes.

**Switching off:** press the OFF key.

#### **Switch-on time input:**

The ignition key must be in position 1 or beyond, and the HOUR function must have been selected.

Every time the TIMER key is pressed, a fan symbol appears on the digital display and alternately 1 and 2 to indicate the selected and input switch-on time.

Once the desired figure has been selected, the appropriate switch-on time can be input.

Press the TIMER key until the dot between the hours and minutes display begins to flash.

Input the desired switch-on time with the h-DAT and min-DAT keys.

Press the TIMER key again: the dot will stop flashing. The switch-on time is then programmed.

**Activating the programmed switch-on time** (ignition key in position 1 or beyond): press the SET-RES key. The LED comes on until the time for the independent heater/ventilation system to start automatically is reached.

The LED above the ON key then confirms that the system is in operation.

**De-activating the switch-on time:** press the SET-RES key again. The LED will go out.

Once programmed, a switch-on time can be activated and de-activated with the SET-RES key as often as required. It remains programmed until a new time input is made.

If the car is equipped with an **on-board computer, the system is operated with the TIMER and S/R keys.**

### ***Independent heater/ventilation system***

Below an outside temperature of 16°C, the **independent heater is ready to operate at any time, including during a journey.**

The switch-on time can be preselected so that the car is warm before the journey starts. This also makes it easier to remove ice and snow from the car in cold weather.

Both the independent heater and the independent ventilation system are programmed to run for 30 minutes. In view of its high current consumption, do not run the independent heater for a further period before the car engine is run.

The independent heater is connected to the car's regular heating system, so that the interior temperature can be preselected at the rotary temperature switches or selector wheels.

#### **Regular heating system:**

- Push the air-distribution slide control up or down, to direct the heated air through either the defroster jets or the front and rear footwell outlets.

- Close the slide controls for fresh-air outlets and on fresh-air grilles on the end of the centre console.
- Set the rotary airflow control to at least 12 o'clock.

#### **Air conditioning:**

Heated air automatically emerges through the defroster outlets and the front and rear footwell outlets. Air distribution by means of the pushbuttons is possible only with the ignition key in position 1 or beyond.

**Note:** after switching off (LED goes out), the independent heater continues to run for a short time.

Above an outside temperature of 16°C, the **independent ventilation system** can be run to ventilate the car's interior and lower its temperature.

#### **Regular heating system:**

- Open slide control as required; the most effective ventilation is afforded by the front fresh-air outlets and those at the end of the centre console.
- Set rotary airflow control to at least 12 o'clock.

#### **Air conditioning:**

Air emerges automatically through the controlled-flow, directional grilles on the fascia. For efficient operation of the independent ventilation system, these grilles must therefore be fully open.

The independent ventilation system is out of action in ignition key position 2.

### Important notes

If the independent fuel-burning heater does not start after not more than **two attempts**, or switches itself off automatically, consult a BMW service station.

**Never run the independent heater in an enclosed space.**

**Always switch off the independent heater before adding fuel to the tank.**

**Recommendation:** operate the independent heater briefly once or twice during the warm period of the year.

At temperatures above 16°C, proceed as follows:

**Time switch:** press the TEMP key for 3 seconds; the letter E will appear.

**On-board computer:** Press the TEMP and TIMER keys simultaneously; the INVERS display will appear.

After this, the independent heater can be operated once.

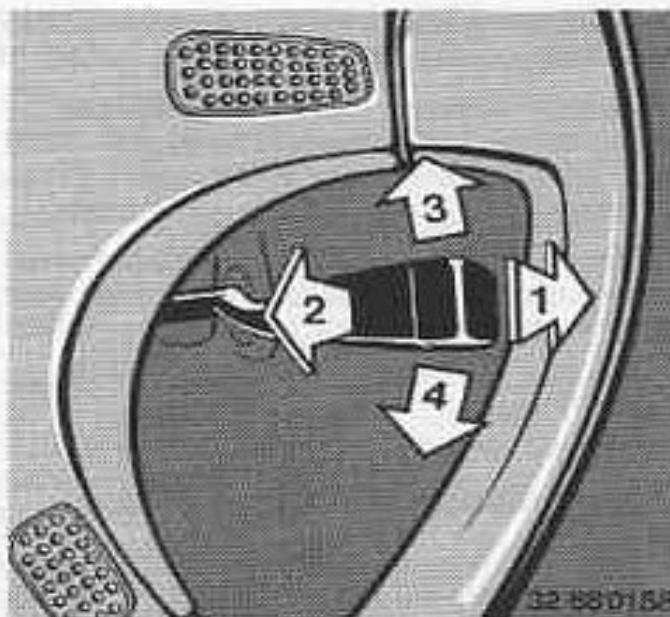

### Automatic cruise control

Any driving speed above app. 45 km/h (28 mile/h) can be held constant and memorised.

Moving lever briefly towards:

#### 1 - ACCEL.

The car's road speed is maintained and the value memorised.

Holding the lever in this position: the car speeds up although the accelerator pedal is not pressed down. As soon as the lever is released, the road speed then reached is maintained and memorised.

After the accelerator pedal has been pressed down, for instance when overtaking, the memorised value is restored.

**Note:** on cars with ASC/EML, when the set value is exceeded by 16 km/h or undercut by 8 km/h, the memorised value must be recalled.

#### 2 - DECEL.

The actual speed is maintained and memorised.

If the lever is held in this position, the car will slow down (throttle closed automatically). The speed reached when the lever is released is then maintained and memorised.

#### One-touch function

To increase or reduce the car's speed by approx. 1 km/h, move the lever briefly as often as required in the ACCEL. or DECEL. direction.

#### 3 - RESUME

The previously memorised speed is restored and maintained.

#### 4 - OFF

**In this lever position, the cruise control system is switched off regardless of the momentary operating or traffic situation.**

**Warning:** do not use the automatic cruise control unless road and traffic conditions permit a constant speed to be maintained.

**To switch off the cruise control:** move the lever briefly to OFF; the system is switched off automatically if the rate of decrease in road speed exceeds 1.5 m/s<sup>2</sup> (4.92 ft/s<sup>2</sup>), for example on uphill gradients, and also if the brake or clutch pedal is depressed or the automatic transmission selector lever moved from D to N.

The memorised speed setting is erased when the ignition key is turned to position 1.

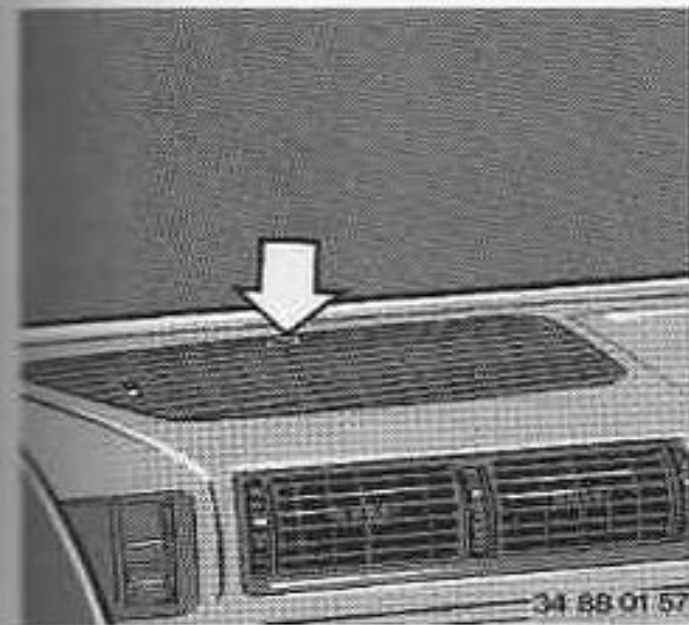

### Acoustic-signal burglar alarm

If an unauthorised person attempts to open a door or lid, an alarm sounds for 30 seconds and the ignition is put out of action.

If he is not deterred and tries, for example, to start the engine or interfere with the radio, glove box or battery, the alarm sounds for a further 30 seconds each time such an attempt is made.

If the car is pushed away, the alarm sounds after a short distance.

The system is **activated and deactivated** with the central inhibit lock for the central locking system.

When it is activated, the LED on top of the fascia remains on for up to 36 hours.

If the LED flashes, the car has not been locked properly (either door, lids and glove box must be closed properly). After a further 10 seconds the system is automatically re-activated and the LED remains on without flashing.

When the system is de-activated, the LED goes out. If it is not de-activated until the LED has already gone out (after 36 hours), the LED will come on briefly and then go out again.

To indicate that the alarm signal has been given, the LED flashes for up to 36 hours. It goes out when the system is de-activated.

The **luggage compartment** is still accessible with the system activated. The LED flashes for 10 seconds as a reminder if the luggage compartment lid has been closed but not locked (to lock, turn key to right and pull out).

If the system cannot be de-activated by the normal routine, follow this emergency procedure:

- open the door with the key; the alarm will sound for 30 s.
- enter the car, close the door and turn the ignition key to position 1. The alarm will sound again for 30 s.
- Wait for the LED to go out (approx. 15 minutes). Do not open the door during this period, nor turn the ignition key away from position 1.
- The system will then be de-activated.

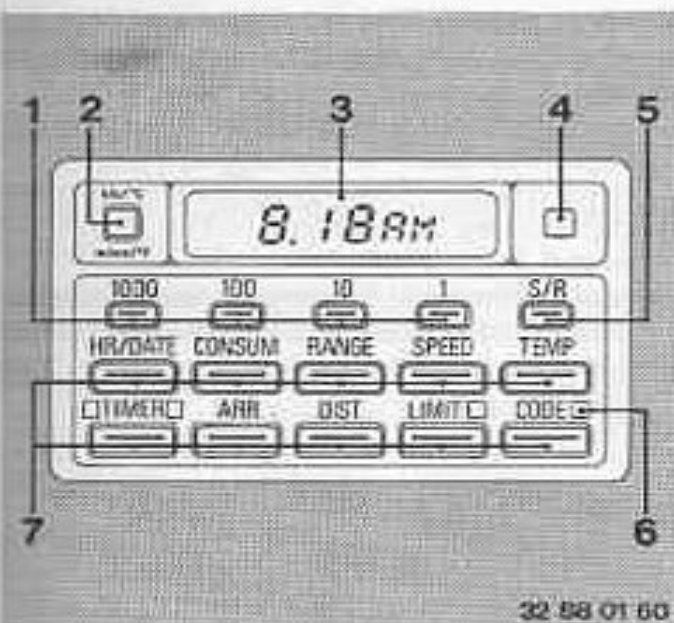

32 88 01 60

### On-board computer

- 1 – Input keys for numerical data
- 2 – Unit of measurement changeover
- 3 – Digital display
- 4 – Photo-transistor for automatic control of display brightness
- 5 – Start-Stop (SET/RESET) key
- 6 – Light-emitting diodes (LEDs)
- 7 – Information keys

The on-board computer can supply the following information outputs for safe and economical driving:

- HR/DATE – Time or date
- CONSUM – 2 average fuel consumption readings
- RANGE – Range on remaining fuel
- SPEED – Average speed
- TEMP – Outside temperature
- TIMER – Stopwatch and 2 switch-on times for independent fuel-burning heater/ventilation system
- ARR – Estimated time of arrival
- DIST – Distance from destination
- LIMIT – Speed limit warning
- CODE – Immobilisation of car

The computer is ready for use at ignition key position 1 and beyond.

For road-safety reasons, always **input information before commencing a journey**, or with the car at a standstill.

Press the appropriate information key to obtain the following displays (no other input is necessary):

- Average speed
- Average fuel consumptions 1 and 2
- Range on remaining fuel
- Outside temperature

After pressing one of the information buttons:

- Average speed
- Average fuel consumptions 1 and 2
- Stopwatch (with independent heater/ventilation if installed)

press the S/R button (4) to restart or stop the computer

Numerical inputs for:

- Time/date
- Speed limit warning
- Switch-on times 1 and 2 for independent fuel-burning heater/ventilation
- Distance from destination (used to estimate the time of arrival)
- Immobilisation of car

are described on the following pages.

After selecting the appropriate information key, the unit of measurement changeover key (2) can be used to display any individual item of information (not applicable to CODE) in either metric or Imperial units.

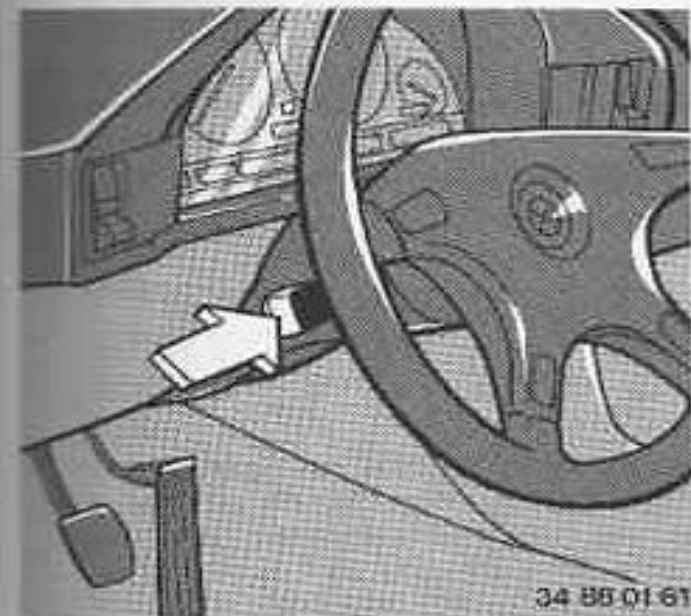

If only a limited amount of information is required on the instrument panel display, proceed as follows:

- Press the turn indicator lever in for 3 seconds, until the PROG 1 display appears (on the on-board computer: P 1).
- Press the desired information keys (if only average fuel consumption 2 but not average fuel consumption 1 is required, press the units of measurement key after the CONSUM key. Each time the changeover key is pressed again, fuel consumption readings 1 and 2 will alternate. The same procedure applies to the date and switch-on time 2 inputs).
- Press the S/R key.

If the power supply to the on-board computer is interrupted, e.g. when changing the battery, all stored data are erased.

Once the power supply is reconnected, the required information data (time, date, speed limit warning and switch-on time if required) must be input again.

Contact a BMW service station if the fault display P P P P should appear.

### Remote control

If the turn indicator lever is pushed in briefly, information is displayed additionally on the instrument panel strip: items can be called up in succession. The on-board computer display remains unchanged when other items are shown on the instrument panel.

To erase the display on the instrument panel, press the Check Control button on the panel or, with the ignition switched on, the CODE key.

Note: the display of Check Control warnings takes priority over information from the on-board computer.

## Computer data input and information displays

Important: input sequence for numbers:

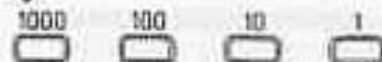











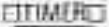

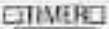



The memory will not accept illogical inputs.

When a number is input, the number stored in the memory is erased; digits can be altered individually in any order.

To input to memory: press the S/R key.

The appropriate numerical display increases by one each time key is pressed or every half a second if the key is held in.

	Input: press keys in the sequence illustrated	Info. display: if an unwanted output is displayed, press approp. information key	Notes on input and information display
Time (Date)	<p>HR/DATE</p> <p>S/R</p>	<p>HR/DATE</p>	<p>If display is ---- HOUR (after power failure), input time again. Clock can be started after input to the nearest second by pressing the S/R key (e. g. when a radio time signal is heard). Date input as for time. After pressing the S/R key the year is displayed. Input the correct year if necessary and press the S/R key again.</p> <p>To obtain date display from other information: press HR-DATE key twice.</p> <p>Hourly signal: in HOUR function, press S/R key; a sound-wave symbol is displayed. Three pips are heard just before each full hour. The time is displayed briefly on the instrument panel strip.</p> <p>To switch off reminder signal: in the HOUR function, press S/R again.</p> <p>To obtain time and date display in ignition key position 0: press the HR-DATE key.</p>
Average consumptions 1 and 2	<p>CONSUM</p> <p>S/R</p>	<p>CONSUM</p>	<p>Recalculated since start of journey when S/R key is pressed.</p> <p>Repeated use of the CONSUM key selects average consumption values 1 and 2 alternately; an indication of which value has been selected appears on the digital display for a short time</p>
Range	-	<p>RANGE</p>	<p>Plus sign (+) in front of display indicates "full tank".</p>
Average speed	<p>SPEED</p> <p>S/R</p>	<p>SPEED</p>	<p>Recalculated from start of journey when S/R key is pressed.</p>

	Input: press keys in the sequence illustrated	Info. display: if an unwanted output is displayed, press approp. information key	Notes on input and information display
Outside temperature	—	TEMP 	Automatic temperature display below +3° C (37.5° F). Gong sounds and unit of measurement flashes for 8 seconds. The temperature value is displayed briefly on the instrument panel strip.
Stopwatch - Start	 → 	—	There is no stopwatch function in cars with an independent fuel-burning heater/ventilation system. When the stopwatch function is running, the LED lights up.
- Intermediate time	—		LED flashes, stopwatch continues to run. Press the TIMER key again: the running stopwatch display will reappear.
- Stop	 → 	—	To stop the stopwatch when another display is shown. Otherwise, simply press S/R. Press S/R again to restart the stopwatch.
Independent heater/ ventilation system - Direct switch-on	 → 	—	When the TIMER key is pressed, the current inputs to the independent heater/ventilation system are displayed. Direct heater operation in ignition key position 1 and beyond. Switching off also possible in key position 0. In the TIMER function, press S/R key only.
- Direct switch-off	 → 	—	
- Preselecting switch-on times: 1 or 2	      	 	Input is possible only when the clock is in operation. With the TIMER function selected, press the key once only; for switch-on time 2, press it again (confirmed on display). When the LED comes on, the heater/ventilation system will run for 30 minutes from the selected switch-on time. During the actual period of operation, the LED flashes. It goes out when the system is switched off. To correct the switch-on time, follow the same procedure as for initial inputs. After selecting the switch-on time inputs 1 or 2, activate or de-activate the timer by pressing the S/R key. When activated, the appropriate LED comes on.

	Input: press keys in the sequence illustrated	Info. display: if an unwanted output is displayed, press approp. information key	Notes on input and information display
Distance to destination	DIST <input type="text"/> <input type="text"/> <input type="text"/> <input type="text"/> <input type="text"/> S/R <input type="text"/>	DIST <input type="text"/>	If the preset distance is exceeded, the additional distance is still counted, but preceded by a minus sign.
Estimated time of arrival	-	ARR <input type="text"/>	The probable arrival time on the basis of the distance input is continuously recalculated according to driving style at any given moment. This information is only available after a distance has previously been input. If the distance has already been completed, the DIST function appears instead of the ARR function. If selected from another function, --- ARR is displayed.
Speed limit warning	LIMIT <input type="checkbox"/> <input type="text"/> <input type="text"/> <input type="text"/> <input type="text"/> S/R <input type="text"/>	LIMIT <input type="checkbox"/> <input type="text"/>	If the input speed limit is exceeded, the LED flashes and a gong sounds. The limit value appears briefly on the instrument panel display. Press the information key again to switch off the speed limit warning: the LED will go out, but the speed value in the memory is retained. To store the speed at any given moment in the memory: in the LIMIT function, press the S/R key.
Code to immobilise car - to activate	Ignition key in position 1 CODE <input type="checkbox"/> <input type="text"/> <input type="text"/> <input type="text"/> <input type="text"/> <input type="text"/> S/R <input type="text"/>	-	Code numbers from 0000 to 9999 can be input. <b>Important: memorise the code number!</b>  Ignition key turned to 0: LED comes on for up to 36 hours.
- to de-activate	Ignition key at 1 or 2 <input type="text"/> <input type="text"/> <input type="text"/> <input type="text"/>  (Input code) Start engine	-	<b>Warning: if 3 incorrect inputs are made consecutively, or 3 attempts are made to start the engine, an alarm sounds for 30 seconds.</b>

## Further information on the on-board computer

Changes in information programs are only possible after pressing the relevant information key.)

### S/R/DATE



The time and date are displayed alternately by pressing the key. The date display disregards leap years and must be corrected manually as appropriate.

### CONSUM



By giving the instruction to restart calculation at a carefully selected moment, average consumption for the entire journey and for part of the journey can for instance be calculated at the same time.

### RANGE



By pressing this key, the estimated distance which can still be covered with the fuel remaining in the tank is computed continuously according to driving style and displayed when selected. Below a range of 15 km (9.3 miles), a flashing four-segment display indicates that more fuel is urgently required.

The on-board computer only registers the addition of fuel in ignition key positions 1 and 2, and when at least 5 litres of fuel are added. A plus sign (+) before the display indicates that the car has a greater range than indicated, as a result of limits in recording fuel level in the tank.

### TEMP



The warning gong sounds again if the temperature has increased to +6°C (43°F) at least once since the last warning signal, then dropped below +3°C (37.5°F) again.

Note that the absence of a low-temperature warning does not mean that ice may not have formed at a temperature above +3°C (37.5°F), for example on bridges or in shadow.

### TIMER



The maximum time which can be measured is 99 hours 59 minutes. The time display shows seconds and tenths of a second for the first minute, then minutes and seconds, and hours and minutes after the first hour. The stopwatch is halted when the ignition key is turned to position 0, and restarts when it is turned to position 1 or beyond.

Independent heater/ventilation system:

If the key is pressed again when other information is being displayed, the following information can be obtained in succession: current situation, switch-on time 2, current situation again etc.

### LIMIT

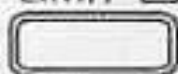

A new speed limit value can be input or displayed. The gong will sound again if the car has slowed down by 5 km/h or more at least once since the gong first sounded and then been accelerated up to the input speed limit again.

### CODE



When the system has been activated, the engine compartment lid, radio and any attempts to start the engine are monitored.

If the engine compartment is not properly closed or the radio is removed, the LED flashes for 10 seconds when the ignition key is turned to 0.

If the ignition key is turned to 1 or 2 with the system activated, the gong will sound and a ---- display will appear. This requires the code to be input. If the engine is started without a code input having been made, the warning gong sounds continuously.

Emergency starting procedure if the code has been forgotten:

- Disconnect and (after app. 5 minutes) reconnect the battery.
- Turn the ignition key to position 1; the alarm will sound.
- A time display will appear and run down to zero for 15 minutes.
- After 15 minutes, the engine can be started.

During the waiting period of 15 minutes, the code can be entered again:

- Press the CODE key
- Input the desired code
- Press the S/R key
- Start the engine.

## Ski bag

The ski bag is a safe, clean method of carrying 3 to 4 (max.) pairs of skis.

The ski bag is 1.20 m long. Together with the space represented by the length of the luggage compartment, skis up to 2.10 m long can be carried. Note that if several pairs of skis are carried in the bag, the available space inside is reduced where the bag becomes narrower, so that only 2 pairs with the maximum length of 2.10 m can be carried.

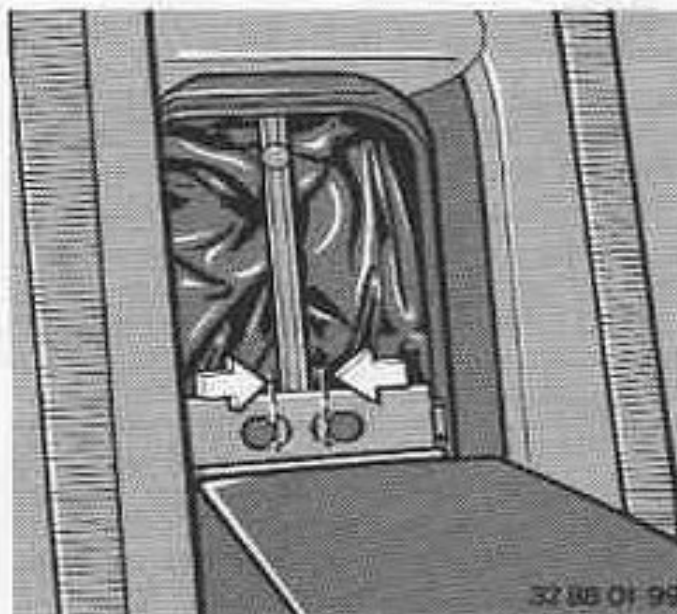

### Loading the ski bag

Fold down the centre armrest of the rear seat and detach the trim at the upper burr fastener.

Press together the two locking levers and lift out the centre armrest.



To release the loading flap in the luggage compartment, press the round knob, then disconnect the retaining loop at the upper hook and lower it.

Spread the ski bag out between the front seats.

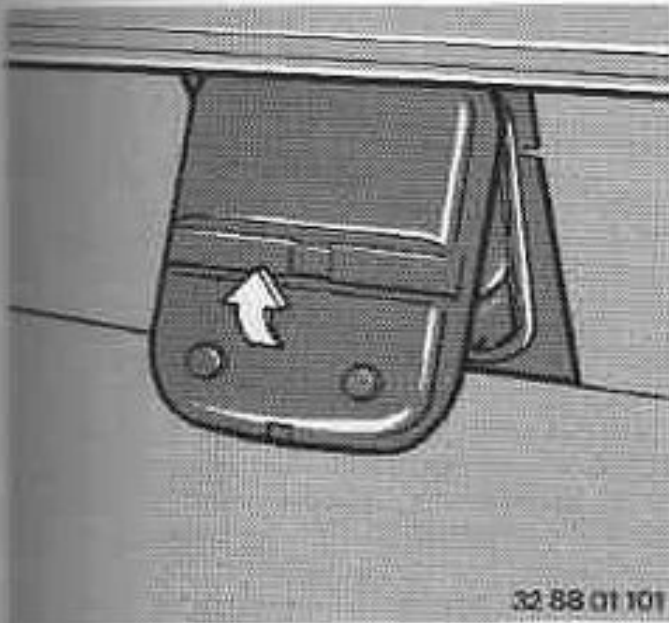

32 88 01 101

If the ski bag is not used for a lengthy period, make sure that it is stored in a dry condition.

This ski bag does not need to be impregnated with commercial products.

However, the material from which it is made is waterproof, and melted ice or moisture condensate should therefore be wiped off after use.

If the ski bag is not needed for a lengthy period, it can be removed and the opening in the luggage compartment sealed off with a cover available as an accessory. This is secured from the luggage compartment side by reusable spreader clips.

Secure the loading flap from the luggage compartment side against the underside of the rear-window shelf, using the magnetic retainer.

Make sure that the skis are clean before they are inserted into the bag, and that there are no sharp edges which could damage it.

## Radio operation

The strength of the signal received by your car radio aerial, and thus its output quality, depend on the position of the receiver and the height and directional location of the aerial.

In this respect, certain concessions have to be made for a mobile radio such as that in a car. The position of the radio is constantly changing, and it is impossible to keep the aerial aligned with the direction of signal transmission. Other disturbance factors are high-tension overhead wires, poor or missing interference suppression on other vehicles, buildings and natural obstacles. Even if your car radio is perfectly tuned and your car is equipped with interference suppression, unavoidable noises and loss of high-quality sound can be quite severe.

### Tubular car radio aerial

To ensure high-quality reception, clean the aerial regularly and apply a special aerial grease to protect against effects of the weather (this is particularly important for motor-driven aerials).

To locate the strongest **FM (VHF) transmitter** in your area, pull the bottom telescopic section of the aerial out until the weaker programme signals are no longer audible. Now adjust the set until optimum reception of the strongest signals is achieved. For best reception quality, the aerial should be fully extended.

**Climatic effects** such as fog, rain and snow can interfere with good radio reception.

As the **strength of sunlight** increases, long, medium and short wave reception is adversely affected. These wavebands can be heard best after dark, when the ionosphere reflects more of the transmitted signals back to earth.

The medium (MW), long (LW) and short (SW) wavebands provide a more extensive or, in some cases, exceptionally wide reception range, since the signals are dispersed not only as **ground waves**, but also as **space waves**, which are reflected back to earth by the ionosphere.

There are physical reasons why the quality of **medium wave** reception is not as good as on FM. Long-distance reception, however, is quite acceptable, particularly at night, so that a large number of stations can be picked up. However, station density is such that mutual interference often occurs.

Sound reproduction on the medium waveband seems rather dull in quality by comparison with FM.

On the **long waveband**, transmitters still farther away than on medium wave can be picked up.

**Short wave** offers the longest theoretical reception distance. Maximum station density and, subject to basic physical limitations, best sound quality, are obtained in the 49-metre band.

The **very-high frequency** transmission system uses the frequency modulation (FM) principle and offers far better sound quality than the other wavebands. However, reception is limited to only a few stations within any area, since the radio waves are emitted in a **straight line** from the transmitter tower, and therefore cover an area not more than approx. 80 km in radius. As the distance between the transmitter and receiver increases, background noise becomes more of a problem, and finally the station can no longer be heard or is displaced by a more powerful one which the car is approaching. This situation can only be avoided by retuning to a stronger signal; something that has to be done relatively frequently when listening to FM transmissions.

**Stereo transmissions**, if available in your area, can normally be received on FM only. As you move away from the transmitter, interference becomes noticeable more rapidly than on mono transmissions. In this case, switch to mono reception or retune to a station providing a more reliable stereo signal.

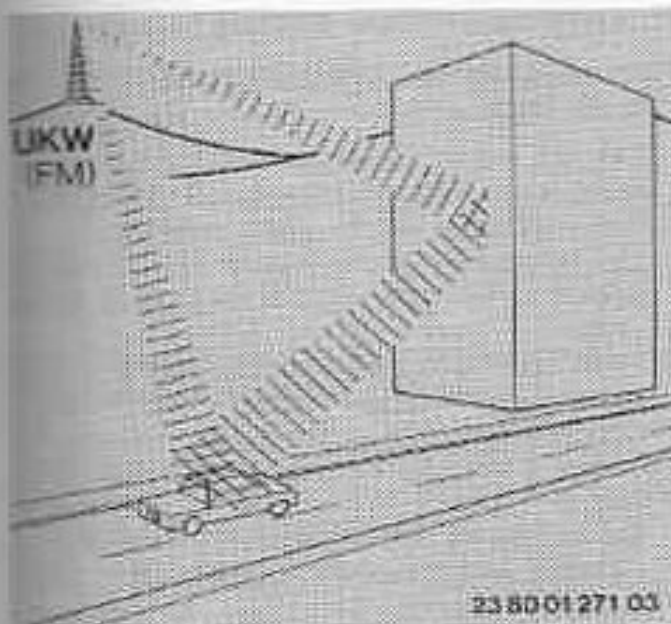

**Hissing, sizzling and splashing noises** occur when reflected signals are picked up by the aerial a fraction of a second after the main signals, from large buildings nearby for example. The sound level also fluctuates repeatedly as a result.

**Continuous background noise** normally indicates that the edge of the transmission zone has been reached, or that the car has been driven into a 'shadow', where no direct signals can be received. The only remedy is to tune to a nearer or more powerful transmitter.

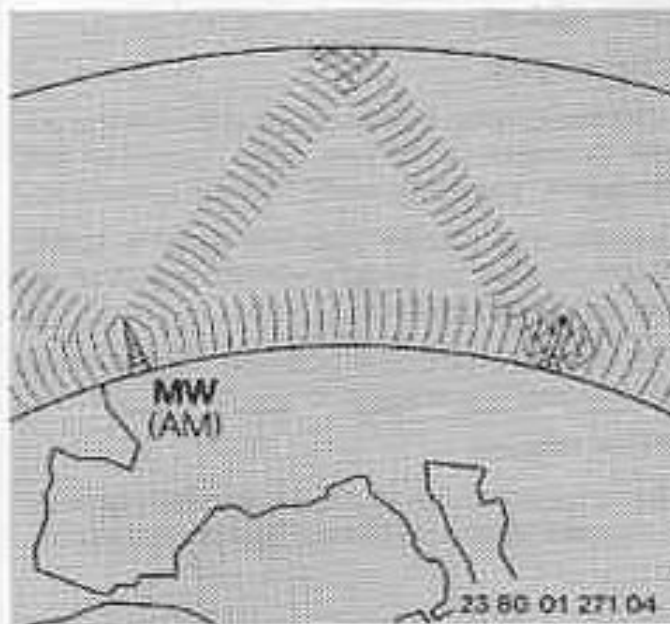

**Severe fade** is a phenomenon more often encountered on medium wave and usually accompanied by distortion. It is caused by the superimposition of ground and space waves at the reception point.

**Fluttering noise** is caused by signal fade, when the line of site between the transmitter and receiver is blocked by large buildings or topographical features. A similar effect is sometimes heard when driving along tree-lined roads.

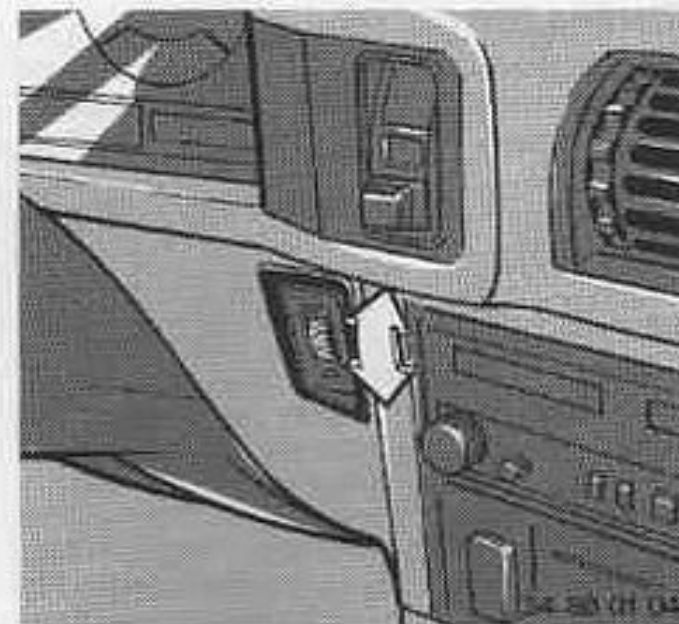

#### **Front-rear balance control**

The relative volume of sound from the front and rear loudspeakers can be varied. In the central (detent) position, the volume is the same at front and rear.

### **Starting the engine**

- Apply the handbrake.
- Move the gear lever to neutral (the automatic transmission selector lever to P or N).
- In particular at low outside temperatures, switch off all electric power consumers and fully depress the clutch pedal.
- **DO NOT DEPRESS THE ACCELERATOR PEDAL WHEN STARTING THE ENGINE.** However, if the engine does not start at the first attempt, e.g. in very cold or hot conditions, press the accelerator pedal half-down when trying again.

#### **Additional notes**

Run the starter long enough for the engine to start, but no longer than 20 seconds without a break. Release the ignition key as soon as the engine starts.

#### **Starter motor repeat lock:**

Before repeating an attempt to start the engine, turn the ignition key back from 1 to 0. This is to prevent re-engagement of the starter pinion while the engine is still turning.

Avoid repeated starting attempts at short intervals, or else the spark plugs will become wet.

#### **In severe frost:**

Observe a 20- to 30-second pause between attempts to start the engine in order to protect the battery.

### **BMW 524 td**

#### **Cold engine**

Hold the ignition key in position 2 until the yellow "preheating" telltale lamp goes out and the green "start readiness" telltale comes on.

Operate the starter until the engine starts. This may take up to 40 seconds at extremely low temperatures.

The accelerator pedal position has no effect on starting the engine.

#### **Warm engine**

The engine can be started immediately when the green "start readiness" telltale comes on.

The engine is automatically controlled to run at an idle speed appropriate to the operating conditions in each case.

Do not allow the engine to reach its normal operating temperature with the car standing still, but drive off straight away at a moderate engine speed.

### **Energy-conscious driving:**

**Fuel consumption** is influenced above all by **driving style**.

- Do not warm the engine up to operating temperature at idle speed and never allow the engine to idle for long periods.
- Do not run the engine up to maximum speed in 1st gear; use it for pulling away only.
- Shift up to a higher gear in good time and make full use of the higher and more economical 3rd, 4th or 5th gears.
- Avoid driving for long periods at full throttle.
- Do not carry any unnecessary weight.
- Comply with the recommended tyre pressures.

#### **Furthermore:**

Energy-conscious driving reduces exhaust and noise levels.

### **Switching off the engine**

Turn the ignition key to position 1 or 0.

### **Catalyst models**

If unburned fuel reaches the catalytic converter, overheating and damage may result.

You should therefore avoid all operating conditions likely to cause unburned or insufficiently burned fuel reaching the catalytic converter, e.g.:

- unnecessarily prolonged operation of the starter motor
- frequent, repeated cold-starts
- allowing the engine to run with the spark plug caps disconnected.

If the ignition should misfire during a journey, drive to the nearest BMW service station, using low engine speeds only.

Engine refinement is influenced by the exhaust emissions purification technology, fuel consumption and the quality of the fuel used.

The modified operating conditions are largely taken into account by the electronic measuring and control functions and the high-quality design and workmanship of individual components, e.g. in individual features such as the electronic ignition and fuel injection system.

The car's altered engine and road behaviour, for instance when accelerating from a low speed, when the combustion process resumes after the cruise control has been in operation and when the engine is running at a low idle speed, reflect the compromise between the need for low fuel consumption, improved environmental acceptability and luxury driving; these differences constitute no cause for concern.

## Running in

Maximum efficiency and a long operating life can be achieved by observing the following notes.

### The first 2000 km (1200 miles)

Drive at varying engine and road speeds.

Do not exceed an engine speed of 4000/min. (BMW 524 td: 3200/min.)

**Important:** do not exceed 2/3 of the maximum road speed in 5th gear.

Do not depress the accelerator pedal to the full-throttle position or allow the kickdown to operate.

### After the first 2000 km (1200 miles)

Road and engine speeds can be increased gradually.

The running-in rules apply not only to the engine, but also to the final drive.

If either of these assemblies has to be renewed later in the car's life the running-in procedure must be repeated.

During the running-in period, a degree of stiffness may be noticed at the gear lever, in the steering and other assemblies. This will disappear after a short while and should be regarded as part of the normal running-in process.

## Tyres

The production methods used in the tyre industry result in brand-new tyres having less than their designed road-surface adhesion. For this reason, you are urged to drive with restraint for the first 300 km (app. 200 miles).

## Brakes

As a means of achieving uniform wear patterns and a good friction coefficient on new brake linings, avoid repeated sudden braking, especially from high speeds, during the first 500 km (app. 300 miles), and also prolonged severe loads, such as when descending lengthy mountain passes.

Brake linings, discs and drums need the distance and treatment stated above to bed down properly and avoid premature wear.

## Handbrake

The handbrake operates in an entirely separate system from the normal service brake and has its own drums, which must also be bedded down correctly.

If road surface, weather and traffic conditions permit, the desired effect can be achieved by applying the handbrake lightly at about 40 km/h (25 mile/h) until definite resistance is felt. Then pull up the lever to the next notch and drive the car about another 400 metres before releasing the handbrake completely.

This procedure will enable the handbrake to operate at maximum efficiency.

During the pre-delivery check, inspection or Safety Test, your BMW service station will bed in the handbrake linings correctly.

You can repeat the process yourself, provided that due care is exercised, at three-monthly intervals, or whenever the handbrake becomes less effective.

### **Fuel quality**

For details, see page 4.

When abroad, make sure that only fuel of the correct minimum quality is obtained.

If you have no choice but to refuel with petrol having a lower octane number than recommended, and thus less knock resistance, observe the following rules to avoid "pinking" or pre-ignition:

Drive at engine speeds between 2500 and a maximum of 4000/min, change gear in good time and accelerate gently and smoothly.

#### **BMW 524 td**

Avoid continuous full-load run if obliged to use fuel with a lower cetane number than recommended. Such fuel will be less willing to ignite.

### **Fuel consumption**

The standard test method used to determine fuel consumption (DIN 70030, Part 1) obtains values which are by no means identical with the car's average fuel consumption in everyday driving. After all, this depends on a variety of factors such as driving style, load, road conditions, traffic density and flow, weather, tyre pressures etc.

For fuel consumption according to DIN standard see page 96.

### **Catalyst models**

**Engines with a catalytic converter in the exhaust system must be run on unleaded fuel only.**

The lead particles contained in leaded fuel would otherwise be deposited on the effective surface of the lambda probe installed to regulate the fuel-air mixture and on the catalytic converter, thus rendering these items useless.

Bear this in mind when driving in countries where unleaded fuel is not always readily available.

### **Additional practical tips**

Do not allow the engine to warm up to operating temperature at idle speed.

At exceptionally low temperatures however, allow the engine to run for about half a minute at a fast idle to ensure that oil reaches all parts of the engine.

Never run a cold engine at high speed, as this will cause rapid wear and shorten its operating life.

When driving under load, accelerating or climbing hills, try to prevent engine speed falling below 1500/min. Shift to a lower gear in good time, particularly on uphill gradients.

When declutching, press the clutch pedal down fully. During normal driving, do not rest the foot on the clutch pedal.

#### **Recommendations**

After a lengthy period in heavy city traffic or in a slow-moving queue of vehicles, let the engine "breathe deeply" by driving for a few kilometres at engine speeds above 3000/min. This will disperse any soot deposits in the combustion chambers.

Always keep the luggage compartment lid closed when driving along to prevent dangerous exhaust fumes entering the car. If you have to drive with the luggage compartment lid open, when transporting a bulky load for example, you are advised to close all the windows and the sliding/vent roof (if fitted) and to run the heating/ventilation blower at a medium to high setting.

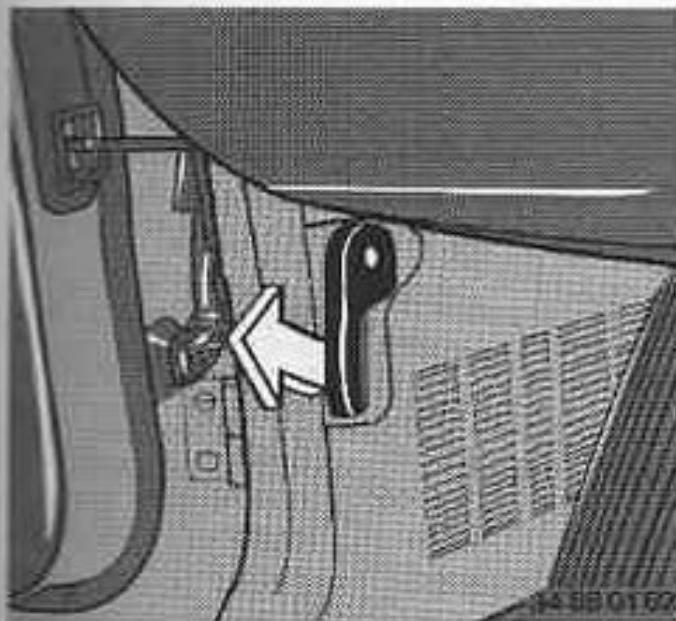

34 88 01 62

### **Engine compartment lid**

To open: pull the lever on the left under the instrument panel.

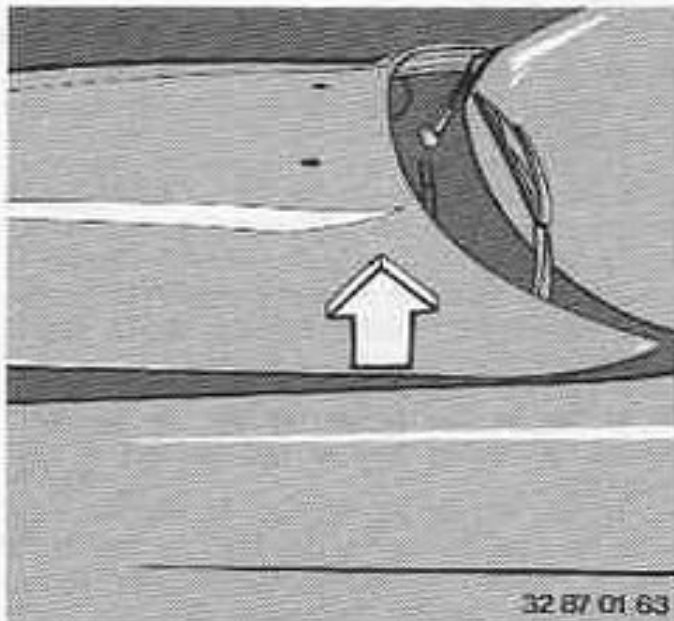

32 87 01 63

A built-in spring mechanism slides the lid forwards automatically to make it easy to open.

### **Engine compartment light**

Comes on when the lid is opened.

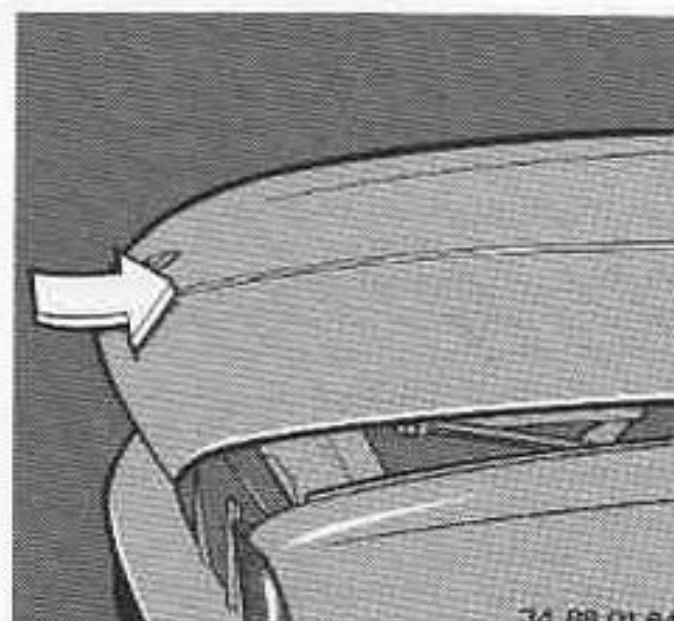

34 88 01 64

To close the lid, push the front evenly on both sides until it is heard to engage.

Raise slightly to ensure that the catches are holding the lid securely.

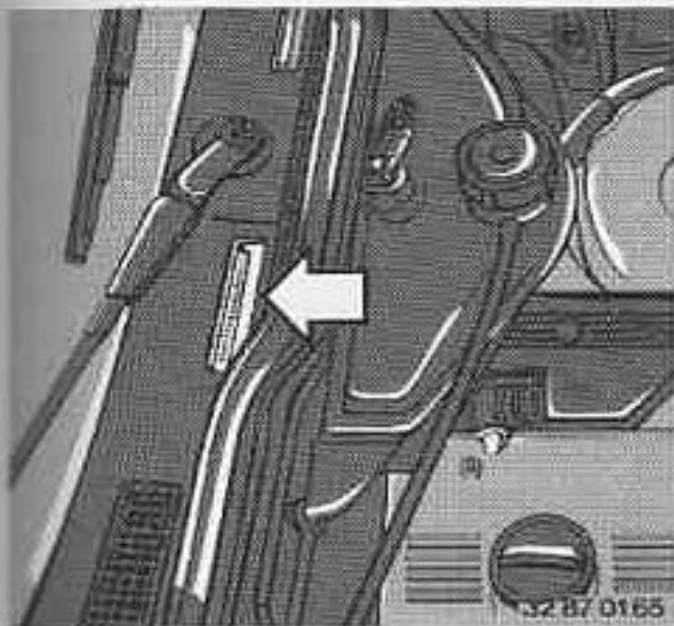

### **Maker's plate**

In the engine compartment, ahead of the right wheel arch.

### **Vehicle identification number**

In the engine compartment, next to the right windscreen wiper pivot.

The information on the maker's plate and the vehicle identification number must correspond with the data stated in the car's documents.

These data are used as a basis for all queries, checks and warranty and parts requirements.

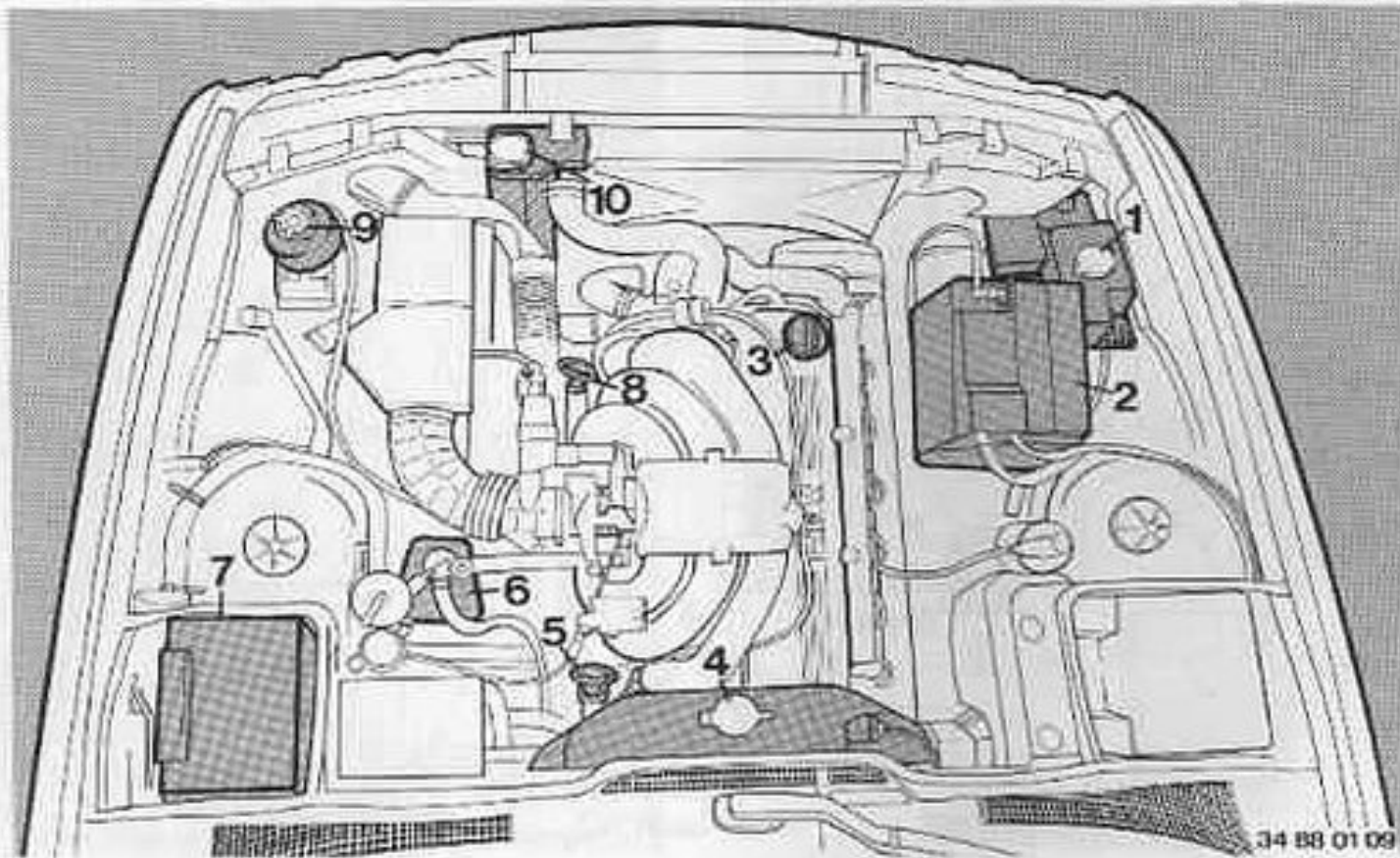

### **Principal items in the engine compartment - BMW 520i, 525i**

- |   |   |
|---|---|
| 1 - Windscreen, headlight and fog light washer fluid tank | 6 - Brake fluid reservoir                           |
| 2 - Battery   | 7 - Fuse box  |
| 3 - Engine oil filler                                     | 8 - Engine oil dipstick                             |
| 4 - Intensive cleaning fluid reservoir                    | 9 - Oil reservoir for steering and brake hydraulics |
| 5 - Automatic transmission oil dipstick                   | 10 - Coolant equalising tank                        |

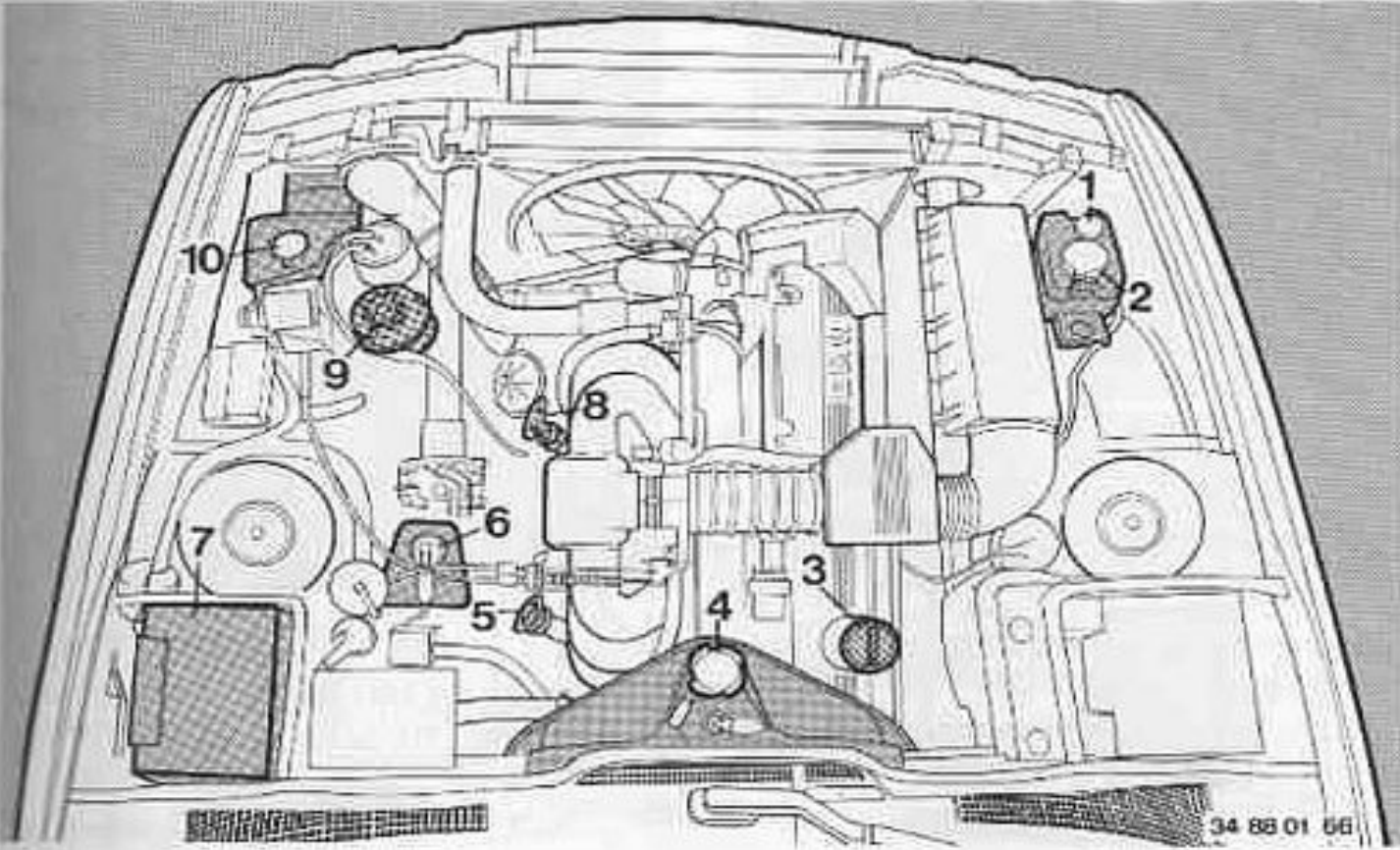

**Principal items in the engine compartment – BMW 530i, 535i**

- 1 – Intensive cleaning fluid reservoir
- 2 – Windscreen washer fluid tank
- 3 – Engine oil filler
- 4 – Coolant equalising tank
- 5 – Automatic transmission oil dipstick
- 6 – Brake fluid reservoir
- 7 – Fuse box
- 8 – Engine oil dipstick
- 9 – Oil reservoir for steering and brake hydraulics
- 10 – Headlight and fog light washer tank

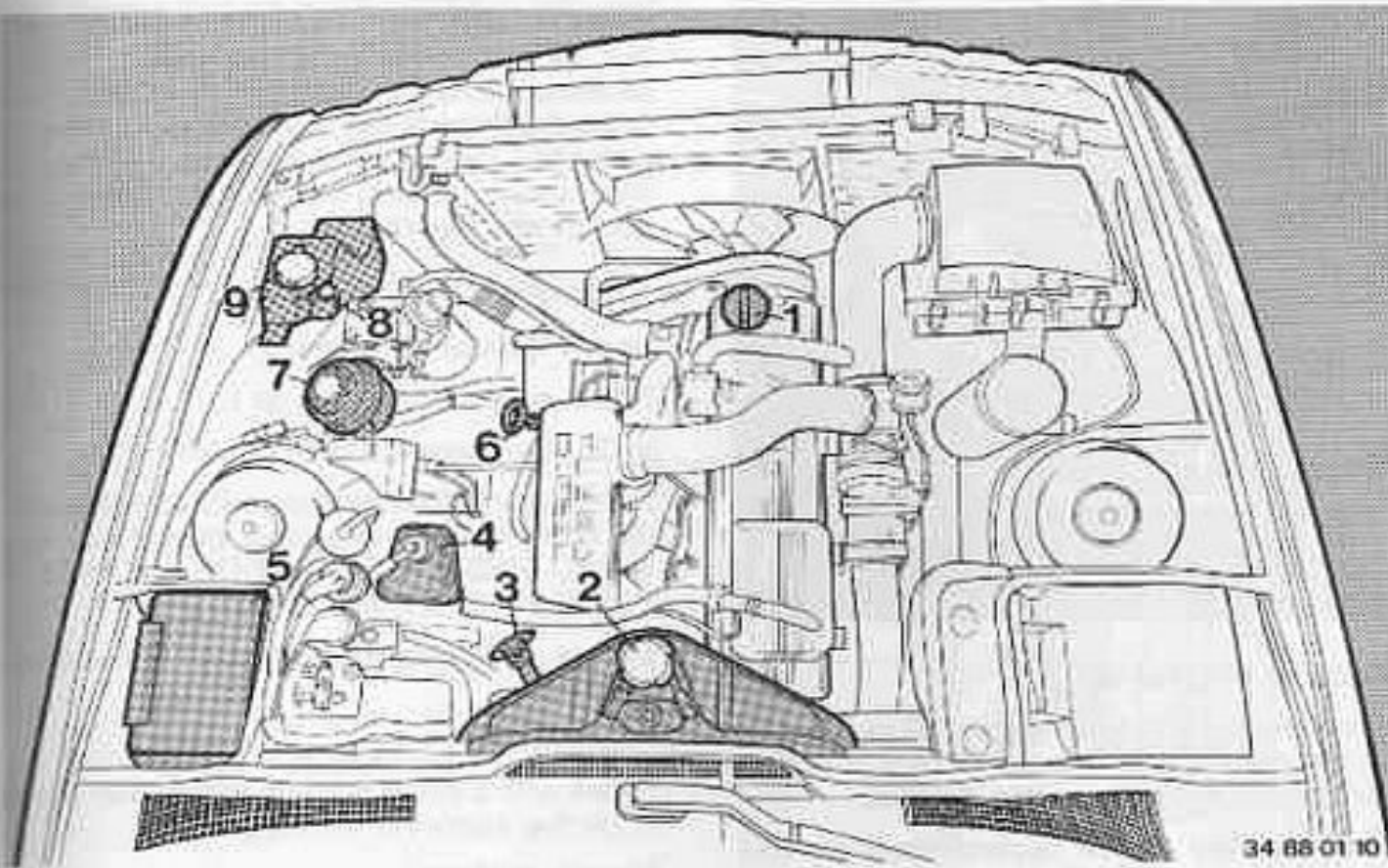

34 88 01 10

### ***Principal items in the engine compartment - BMW 524td***

- |   |   |
|---|---|
| 1 - Engine oil filler                   | 6 - Engine oil dipstick                                   |
| 2 - Coolant equalising tank             | 7 - Oil reservoir for steering and brake hydraulics       |
| 3 - Automatic transmission oil dipstick | 8 - Intensive cleaning fluid reservoir                    |
| 4 - Brake fluid reservoir               | 9 - Windscreen, headlight and fog light washer fluid tank |
| 5 - Fuse box                            |   |

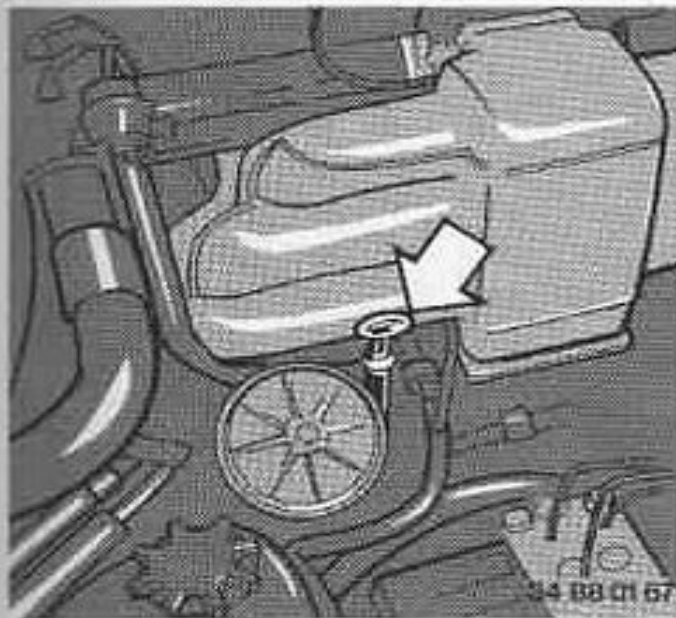

### Engine oil consumption

Max. 0.15 litre per 100 km (app. 250 miles per pint). Like fuel consumption, engine oil consumption depends on the way in which the car is driven and operating conditions.

### Checking engine oil level

Check the level regularly, for example always when adding fuel. When checking, the car should be standing on a level surface.

For maximum accuracy:

Check the oil level before starting the engine, while it is cold. If the engine is warm, allow time for the oil to drain back into the sump (for instance, as long as it takes you to fill the fuel tank).

Insert the dipstick fully.

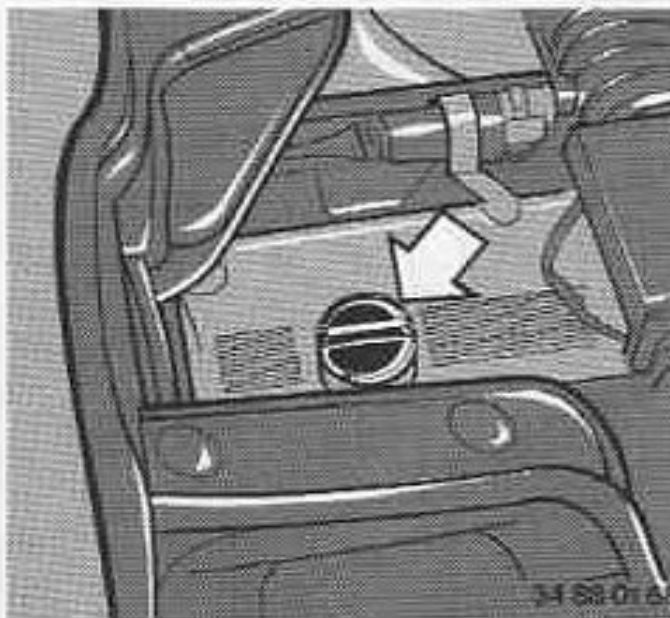

### Adding engine oil

If necessary, add fresh engine oil at the filler on the cylinder head cover. Do not fill above the maximum mark on the dipstick.

The quantity of oil represented by the space between the two marks on the dipstick is app. 1 litre (1.8 pints). Adding too much oil serves no useful purpose and harms the engine. Since excess oil is burned off rapidly, the engine would appear to be consuming excessive oil.

Do not add fresh oil until the level has dropped almost to the lower mark on the dipstick. However, never allow the oil level to fall below this mark.

BMW engines are designed to operate without oil additives, provided that a highly-developed brand-name lubricating oil is used. Indeed, additives may actually lead to engine damage. The same applies to the manual gearbox, automatic transmission, final drive and power steering.

### Engine oil specifications

#### Spark-ignition engines:

Brand-name HD engine oil to

Quality grade CCMC-G2 (API-SF).

specification. Combination with diesel engine oil specifications are also permitted, e.g. CCMC-G2/D1, CCMC-G2/D2, CCMC-G2/PD1 (API-SF/CC, API-SF/CD).

Before using special low-friction oils of quality grade

CCMC-G3,

check with a BMW service station that the oil is on the factory's approved list.

#### Diesel engines:

Brand-name HD engine oil to

Quality grade CCMC-PD1 (API-SF/CD)

Comply with local environmental protection laws when disposing of old oil.

**Recommendation:** have oil changes carried out only by a BMW service station.

The correct SAE viscosity grade to be used depends on outside temperatures, and therefore on the time of year.

The chart on the right indicates the correct SAE grade of engine oil for various prevailing air temperatures.

Note that the temperature limits quoted may be departed from, but only for brief periods.

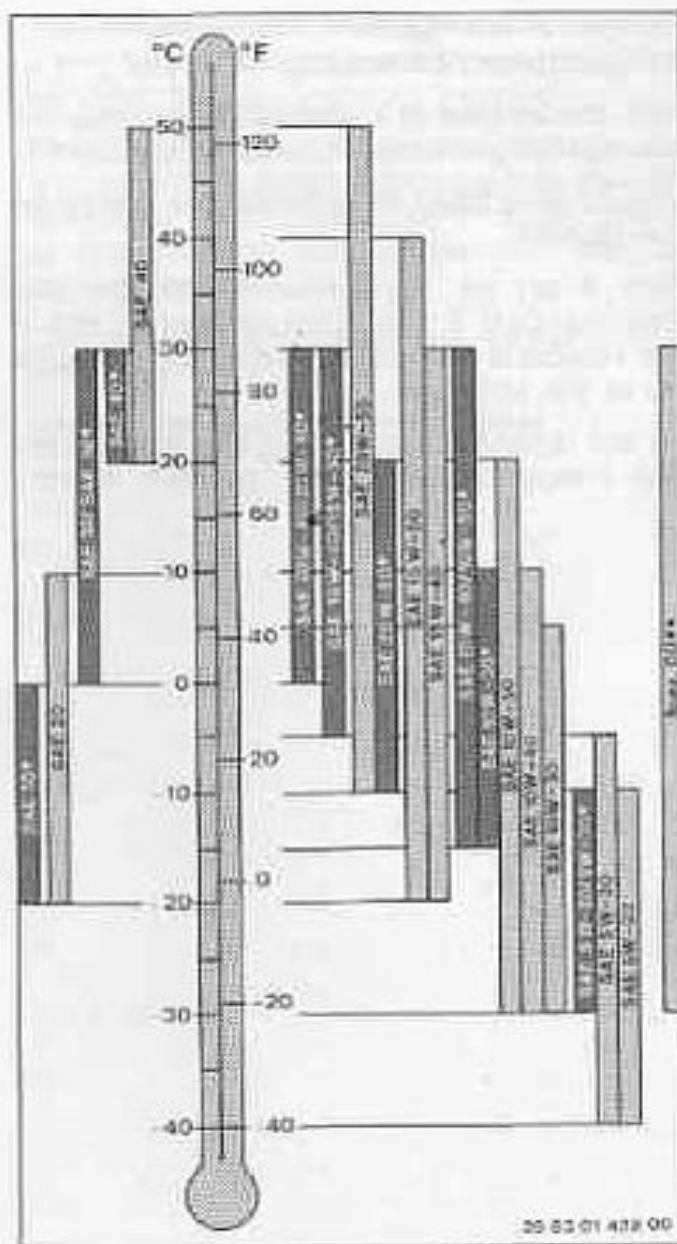

\*) For diesel engines, CCMC-PDI specification

\*\*) Special (low-friction) oils individually approved by BMW

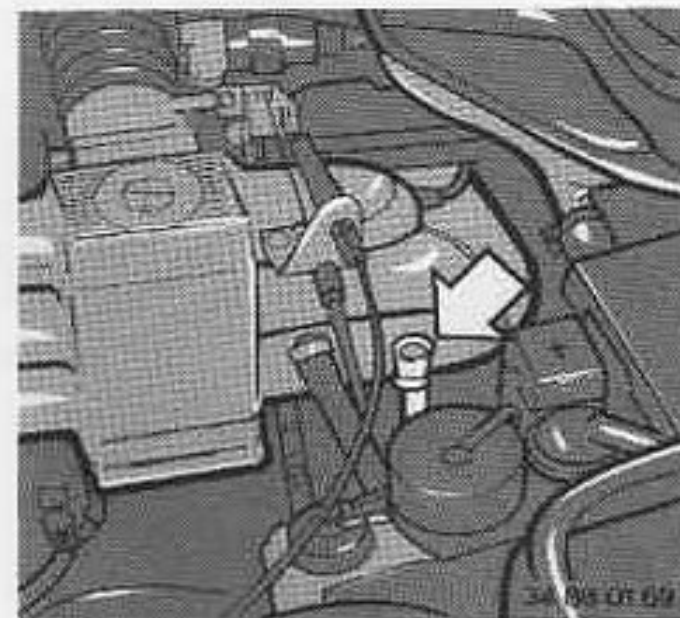

### Automatic transmission: checking oil level

The car must be standing on a level surface with the transmission at operating temperature (80°C). Allow the engine to idle with the selector lever at P or N.

Pull out the dipstick, wipe it with a **non-fluffy cloth** and push it back in to measure the oil level. It must be between the two notch marks.

The quantity of oil represented by the space between the two marks on the dipstick is app. 0.3 litre (0.53 Imp. pint) when the transmission is at operating temperature.

If necessary, add fresh automatic transmission fluid at the oil inspection and filler pipe. BMW service stations know the approved grades.

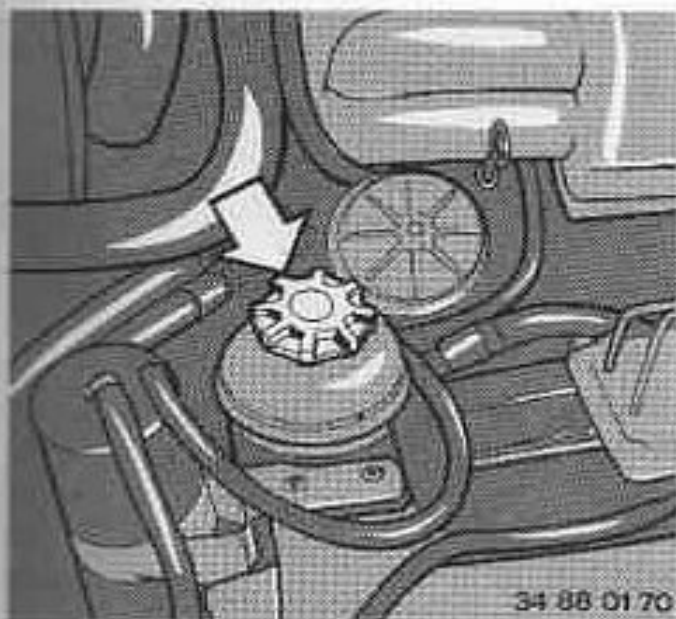

34 88 01 70

### **Steering hydraulics: checking oil level**

With the engine at a standstill, unscrew the reservoir cover and fit again.

The oil level must be between the two marks on the dipstick.

Top up oil if necessary. BMW service stations know the approved grades.

**Allow the engine to run for a while.** Top up the oil if necessary until the level is between the two marks.

Switch off the engine. The oil level may rise app. 5 mm (0.2 in) above the upper mark.

Screw the reservoir cap on tight.

### **Power steering and self-levelling suspension: checking oil level**

With the engine at a standstill, unscrew the knurled nut and take off the reservoir cover.

The oil level must lie between the marks on the dipstick.

Add fresh oil if necessary. Always use Pentosin CHF 7.1 or, if not available, LHM. If the vehicle is carrying a load, do not fill quite up to the top mark.

Fit the reservoir cap and tighten the knurled nut. Ensure that the cap is properly fitted.



34 88 01 71

### **Brake fluid reservoir**

The oil level must be up to the top (MAX) mark. The level can be checked without removing the cap.

BMW service stations know the approved grades of brake fluid.

**Warning:** brake fluid is hygroscopic. That is to say, it gradually absorbs moisture from the atmosphere. To ensure that the brakes on your car remain fully operational, **have the brake fluid changed once a year** by a BMW service station.

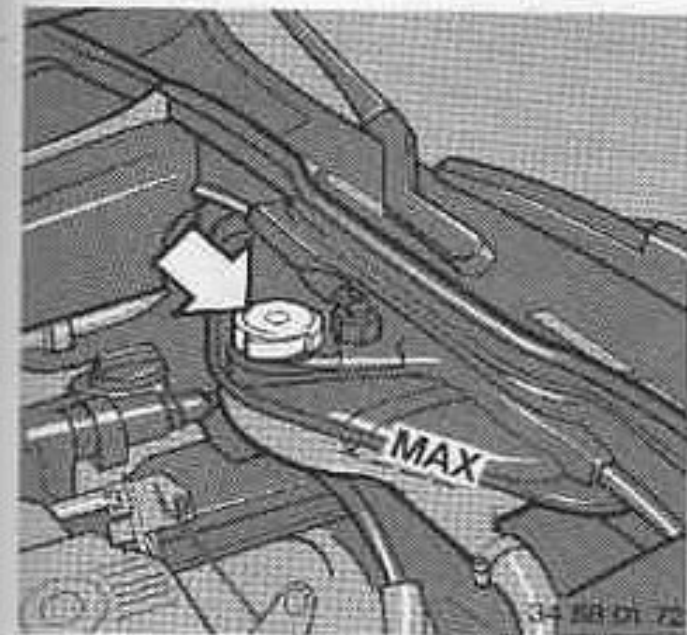

### Checking coolant level

The level must be up to the MAX mark on the transparent equalising tank.

Illustrated: BMW 530i, 535i. Other models: see "Principal Items in the engine compartment".

**Take off the cap only when the engine is cold** (with the needle on the coolant gauge in the bottom one-third of the scale), **otherwise there is a risk of scalding.**

Turn the cap counter-clockwise slightly to allow excess pressure to escape before opening.

Overfilling causes coolant to escape via the overflow pipe.

**Warning:** never add water to the radiator while the engine is still hot.

The cooling system is designed for filling with a long-life antifreeze and corrosion inhibitor. No other additives should be used.

To avoid possible subsequent damage, use only a factory-approved nitrite-free long-life antifreeze and corrosion inhibitor. BMW service stations are familiar with the approved grades.

**Coolant concentration:** see winter operation, Page 79.

**Renew the coolant every 2 year.**

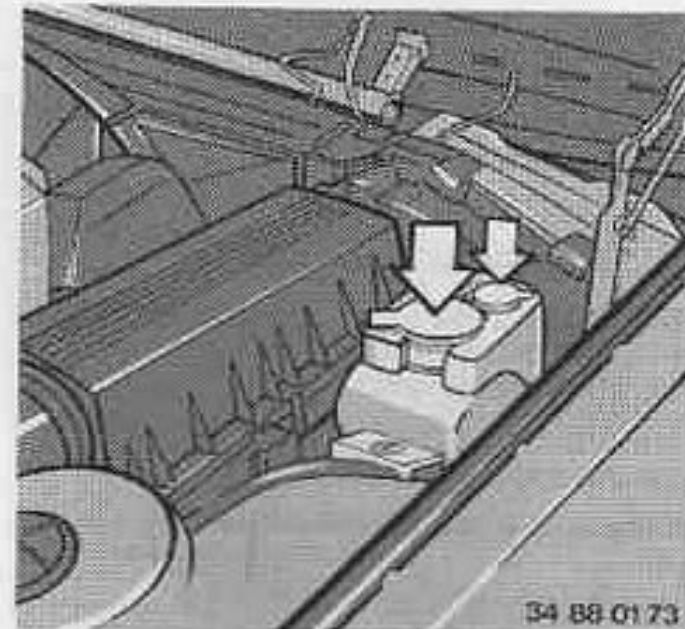

### Windscreen, headlight, fog light and intensive cleaning system reservoirs

Illustrated: BMW 530i, 535i. Other models: see "Principal Items in the engine compartment".

#### Capacity

Windscreen washer system: app. 4.0 litres (7.0 pints).

(BMW 524td: app. 3.7 litres (6.5 pints))

In conjunction with headlight and fog light cleaning system:

app. 8.5 l (15.0 pints) – BMW 520i, 525i

app. 9.0 l (15.8 pints) – BMW 524td.

Headlight and fog light cleaning system: app. 8.0 l (14.1 pints) – BMW 530i, 535i.

Top up with water and, when necessary, and in particular at low outside temperatures, antifreeze in accordance with the manufacturer's instructions.

**Intensive cleaning system:** capacity app. 1 litre (1.8 pints).

Top up with intensive cleaning fluid (frost protection down to  $-27^{\circ}\text{C}$ ; available from BMW service stations).

### **Windscreen washer jets**

The jets of fluid should strike the windscreen at a suitable point to ensure effective cleaning even at high road speeds.

If necessary, adjust by inserting a needle and moving the jets.

### **Headlight and fog light cleaning system jets**

Your BMW service station will reposition these jets on request.

## **Battery**

The battery needs no maintenance and complies with DIN 43539 standard, Part 2. The electrolyte added initially should normally last for the life of the battery.

If the acid level falls too low, for instance after a long stay in a hot climate, top up with distilled water (not acid).

The acid level should be level with the marks visible in the cell opening, app. 5 mm (0.2 in) above the tops of the plates.

Keep the upper part of the battery dry and clean.

### **Important notes:**

1. Particles containing acid or lead oxide must never be allowed to contact the eyes, skin or clothing. If this does occur, rinse off immediately with clean water and consult a physician in the event of injury.
2. Never short-circuit the battery poles: the resulting arc could cause severe injury.
3. Never bring a naked flame near the battery or cause any sparks in its vicinity. This could lead to an explosion.
4. Never detach the battery leads when the engine is running, or else an overvoltage will occur and damage the car's electronic equipment beyond repair.
5. To recharge the battery without removing it from the car, the engine must be stopped and the battery leads disconnected.
6. Before attempting any work on the car's electrical system, always disconnect the negative lead from the battery to avoid the risk of short-circuits.
7. If the car is laid up out of use for an extended period (see Page 78), remove the battery, have it charged and store it in a cool place where there is no risk of frost damage. The battery must be recharged after no longer than 3 months, or else it will be damaged and rendered useless.

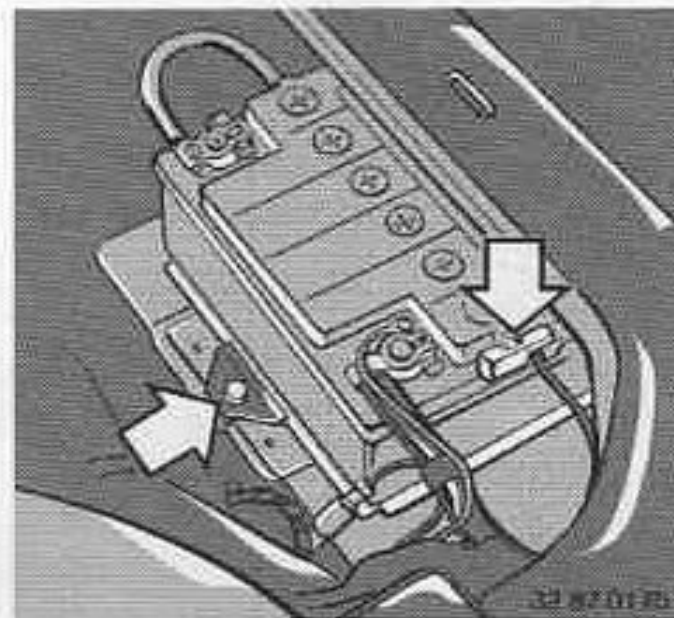

### **Removing the battery**

BMW 520i, 525i: in engine compartment.  
BMW 530i, 535i, 524td: beneath rear seat.

To remove, lift up the rear seat if appropriate. Disconnect the negative lead first, then the positive lead. Pull off the gas trap tank at the side. Unscrew the battery retaining bar. When installing, connect the positive lead first, then the negative lead.

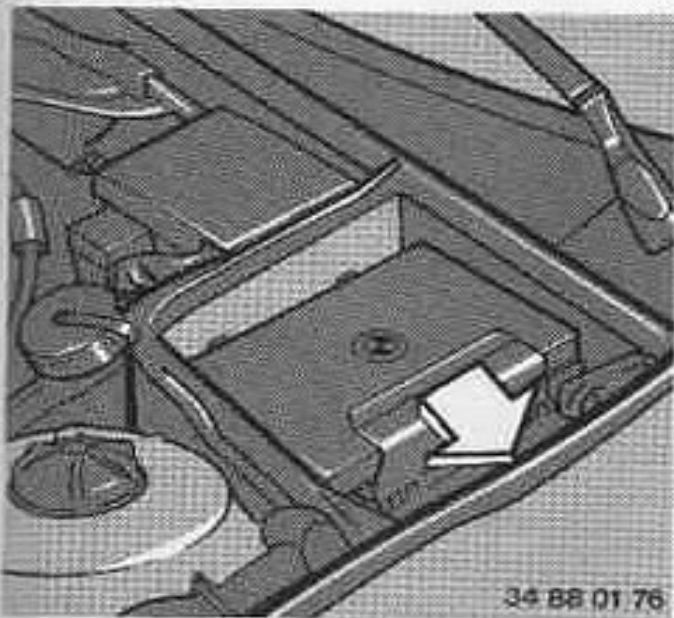

## Fuses

If an item of electrical equipment should fail, switch it off and check the fuse.

The **fuse box** (power distribution box), with spare fuses, relays and plastic tweezers is located in the engine compartment on the left.

Take off the fuse box cover by pressing the hoop to one side.

Pull the blown fuse out of its socket with the plastic tweezers. If the metal strip inside the fuse has melted, the fuse must be renewed, using a fuse of the same rating.

**Never attempt to repair blown fuses.**

To close the fuse box, push the cover down and press the hoop on at the side. If a fuse blows repeatedly, have the fault repaired by a BMW service station.

### Ratings in Amperes and equipment supplied

- 1 = 7.5 A Brake lights, instrument cluster
- 2 = 7.5 A Low and high beam headlight relay
- 3 = 7.5 A Headlight flasher
- 4 = 7.5 A Left side/parking light
- 5 = 10 A Right side/parking light
- 6 = 7.5 A Turn indicator, hazard warning flashers
- 7 = 15 A Fog lights
- 8 = 7.5 A Rear fog lights
- 9 = 15 A Horn, air conditioning compressor
- 10 = 7.5 A Left low beam headlight
- 11 = 7.5 A Right low beam headlight
- 12 = 15 A Mirror adjustment, reversing lights
- 13 = 7.5 A Left high beam headlight
- 14 = 7.5 A Right high beam headlight
- 15 = 7.5 A Independent heater
- 16 = 30 A Front seat heating
- 17 = 7.5 A Instrument cluster, electric window lifts
- 18 = 15 A Burglar alarm
- 19 = 30 A Heater blower
- 20 = 7.5 A Check Control
- 21 = 7.5 A Interior, glove box and luggage compartment lights
- 22 = 30 A Windscreen wipers
- 22 = 15 A Windscreen washer
- 23 = 7.5 A Fuel pump
- 24 = 15 A Wash/wipe
- 25 = 30 A Auxiliary fan
- 26 = 30 A Cigarette lighter
- 27 = 15 A Electronic heating control
- 28 = 15 A Servotronic

- 29 = 7.5 A Air conditioning compressor relay, auxiliary fan, antilock brake system, rear-window heating

Fuses under left side of rear seat:

- 30 = 7.5 A Central locking system (driver's door)
- 31 = 7.5 A Central locking system (other doors, luggage compartment lid)
- 32 = 15 A Seat-belt catch release
- 34 = 30 A Central locking, interior light
- 35 = 30 A Heated rear window
- 36 = 30 A Radio
- 41 = 30 A Radio
- 42 = 30 A Driver's seat: electric adjustment and heating
- 43 = 30 A Passenger's seat: electric adjustment and heating
- 44 = 30 A Wipers/washer
- 46 = 30 A Heated rear window
- 47 = 30 A Central locking, electric sliding/vent roof, electric window lifts

This list contains the principal items of electrical equipment, but not the various electronic functions, which are often cross-connected.

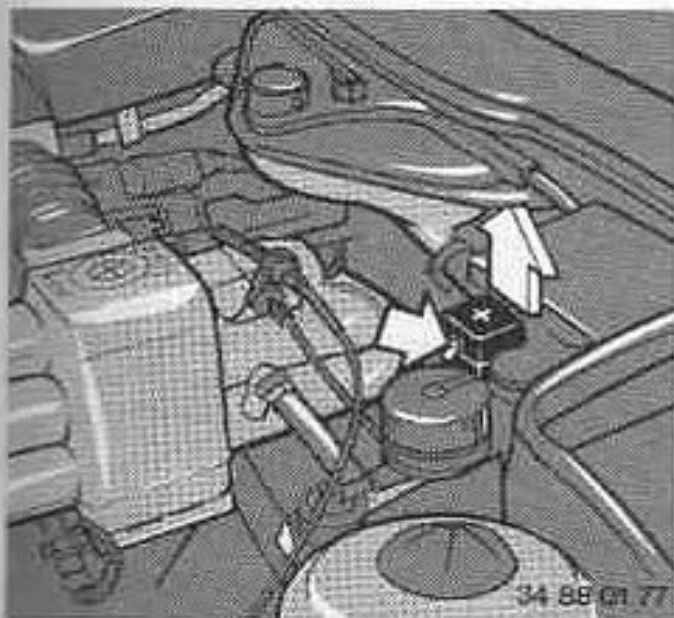

### Starting with a flat battery

If the battery is run down, the engine can still be started by connecting jump leads (BMW accessory) from a second vehicle.

1. Check that the second car has a 12 V electrical system and a battery of approximately the same capacity in Amp/h (this will be marked on the battery).
2. Leave the flat battery connected to the car's electrical system.
3. Do not allow the bodywork of the two cars to touch, or a short-circuit may be caused.

4. First connect the positive terminals of the two batteries together. BMW 530 i, 535 i, 524 td: a special connection is provided in the engine compartment for this purpose (cap marked "+"; pull flap to remove – see illustration). Then connect the second lead to the negative post of the second car's battery and to some part of your car's bodywork or engine block, as far away from the battery as possible.
5. If the battery of the second car is also weak, run its engine to boost the charge. Start your own car's engine in the usual way and keep it running. After the engine has started and **before disconnecting the jump leads**, switch on the lights, rear window heater and maximum heater blower speed to avoid an overvoltage between the governor and consumer equipment. Disconnect the jump leads in the opposite order to that described above. Depending on the cause of the fault, have the battery recharged.

#### Warning:

The car is equipped with a high-performance ignition system and any contact with live components while the engine is running could cause a **fatal electric shock**.

### Toolkit

The toolkit is located on the underside of the luggage compartment lid. Access is by unscrewing the wing nut.

### Warning triangle

This item is stored ready to hand in the toolkit.

**Comply with legal requirements with regard to carrying a warning triangle.**

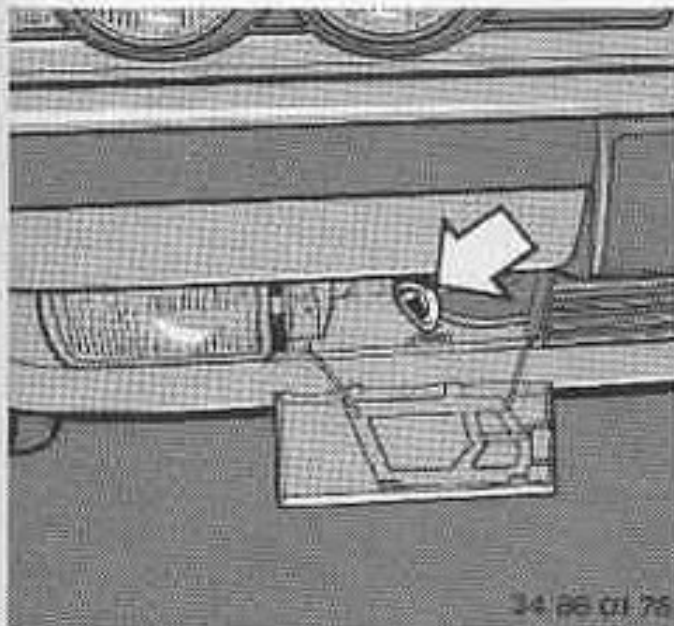

34 86 01 75

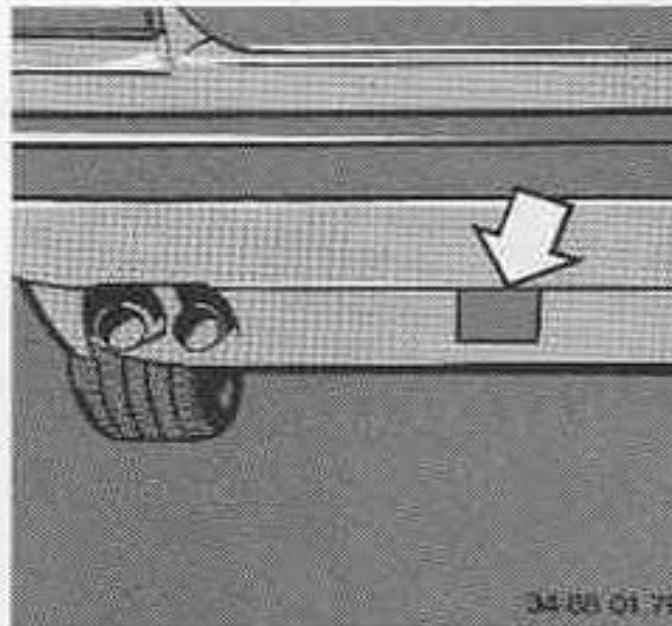

34 86 01 75

### Towing facilities

Front towing eye on right: remove the cover.

Rear towing eye: press the cover panel out, using a screwdriver inserted at the arrows.

Use nylon towropes or straps which are resilient enough to protect both vehicles against sudden jerking. Alternatively, a towbar may be used.

When using a towbar, both cars's towing eyes should be on the same side.

If the towbar runs at an angle, note the following: -

- The amount of free movement between the cars is limited on bends

- The angle of the towbar gives rise to lateral forces (particularly dangerous on slippery road surfaces)
- Do not attempt to steer the car being towed along the same line as the towing vehicle
- There is a danger of the towed car jack-knifing when the towing vehicle is braked.

**Important:** the vehicle being towed should not be heavier than the towing vehicle.

### Tow-starting

Switch on the hazard warning flashers if required by law (note national regulations). Switch on the ignition, engage 3rd gear and keep the clutch depressed. When the car has reached a fair speed, engage the clutch; de-clutch again when the engine starts. Switch off the hazard warning flashers. The cause of poor starting should be investigated and put right by a BMW service station.

### Cars with automatic transmission

Cars with automatic transmission must not be tow-started.

To start the car if the battery is flat, use jump leads as described on the previous page.

### Towing away

If the vehicle has to be towed away, turn the ignition key to position 1 so that the brake lights, turn indicators, horn and wipers are operational.

Switch on the hazard warning flashers if required by law (comply with national regulations).

If the electrical system is out of action, the towed car must be identified as such (for instance by placing a notice or the warning triangle in the rear window).

### Cars with automatic transmission

Selector lever at N.

Max. towing speed 50 km/h (31 mile/h).

Max. towing distance 50 km (31 miles).

To tow the car for greater distances, add 1 litre (1.8 pints) of ATF to the transmission or remove the propeller shaft.

After repairing the car, remember to reduce the fluid level in the transmission again.

**Warning:** when the engine is not running, the power assistance for the brakes and steering does not operate. Increased effort is then required to operate these systems.

### **First aid box**

This item is stored in a holder under the front passenger's seat. Pull it out forwards when needed.

When replacing, ensure that it engages into position properly.

Note legal requirements with regard to carrying a first aid kit.

### **Fire extinguisher**

Holder on the driver's seat.

To ensure full operational reliability, have the fire extinguisher examined by an authorised service station every 2 years.

If required, BMW service stations will carry out this check together with routine annual servicing work.



### **Wheel changing**

Apply the handbrake and select 1st or reverse gear. On automatic transmission cars, select P.

If a tyre punctures, protect the car by switching on the hazard warning flashers and positioning a warning triangle or flashing lamp at an appropriate distance behind the car. Note legal requirements in this respect.

### **Spare wheel**

Located under the luggage compartment floor mat. Unscrew the wing nut by hand.

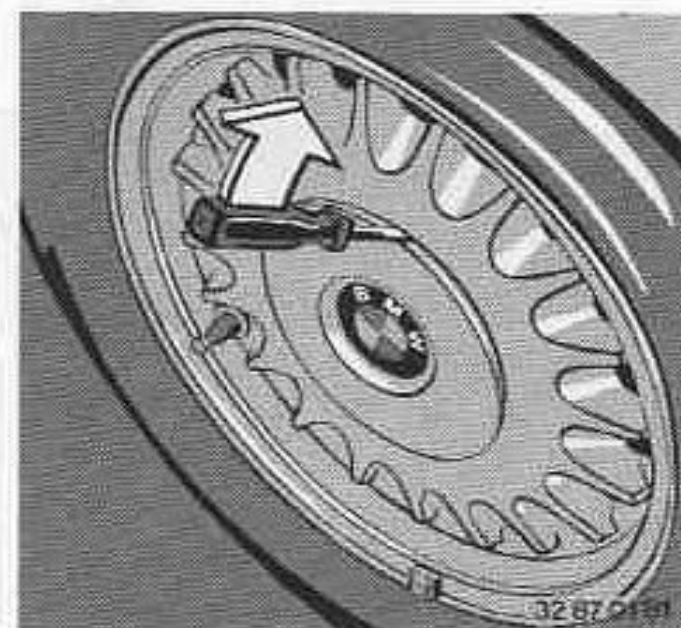

### **Car jack and wheel stud wrench**

Located on the right of the luggage compartment. Lift up the luggage compartment floor mat, take off the trim (by opening the quick-release fasteners). To prevent noise after putting the jack back in the luggage compartment, retract it fully and secure it in its original position with the wing nut.

### **Wheel chock**

The wheel chock is located in the luggage compartment next to the jack and held firmly to prevent noise. Depending on the slope, place the chock in front of or behind the opposite rear wheel to prevent the car from rolling away when it is lifted by the jack.

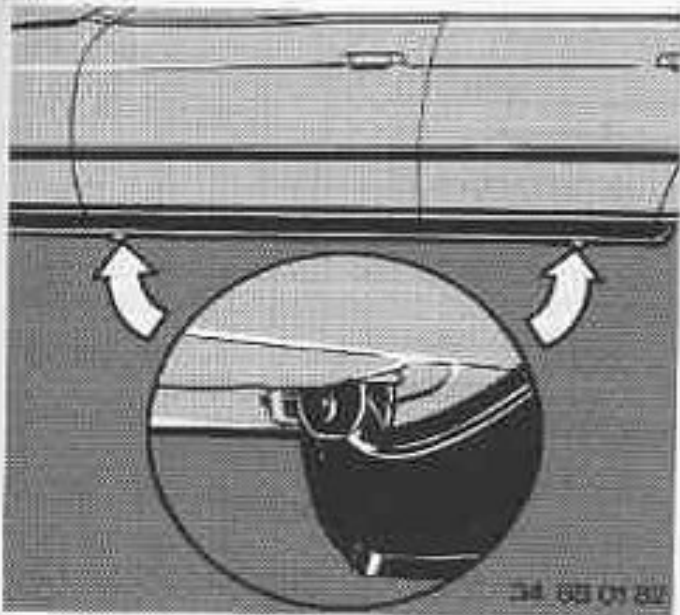

Pressed-steel wheels: remove the full-width wheel cover by hand.

Light-alloy wheels: press off the wheel stud cover with a screwdriver. Light-alloy wheels with wheel studs in the form of a large hexagon: remove cover with hexagonal-socket wrench (in luggage compartment next to car jack base) and turn anticlockwise to remove (bayonet catch).

Loosen the wheel studs.

Attach the jack to one of the **four pick-up points** so that the foot of the jack is squarely on the ground. Turn the jack handle until the wheel is clear of the ground.

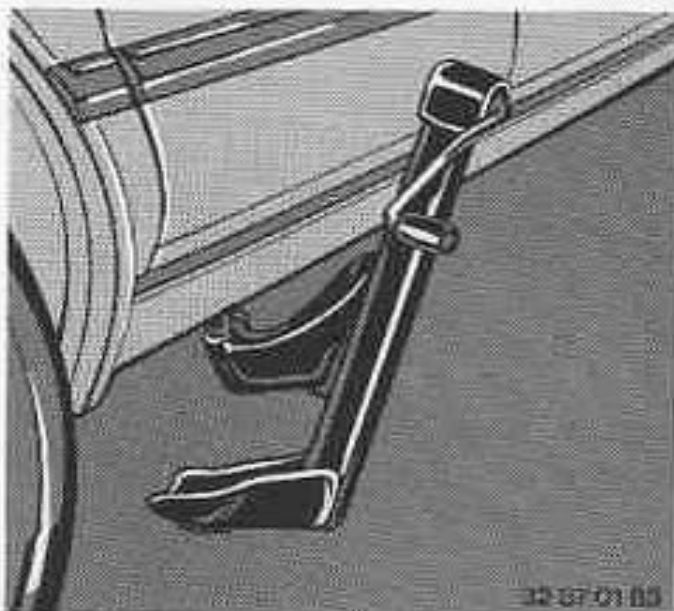

**Warning: never lie underneath a jacked-up car, or else you risk a fatal accident.**

Unscrew and remove the wheel studs and change the wheel.

To fit the new wheel, insert the centring pin from the toolkit into one of the tapped holes. Place the wheel on the pin, screw in one wheel stud, then remove the pin. Screw in the remaining wheel studs and tighten them uniformly.

Lower the car with the jack. Tighten the wheel studs firmly in a crosswise pattern (first one stud, then another on the opposite side of the wheel). For safety reasons, have the tightening torque (110 Nm) checked with a calibrated torque wrench at the earliest opportunity.

When a wheel is installed for the first time (e.g. the spare wheel), check the tightening torque after the first 1000 km (600 miles).

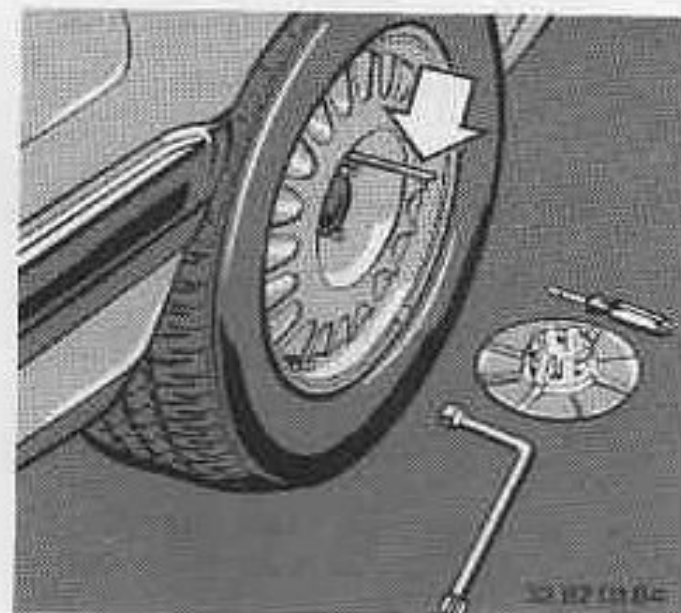

When fitting other than Genuine BMW light-alloy wheels, it may be necessary to use the corresponding wheel studs in place of the standard BMW studs.

To attach the **full-width wheel cover**, the tyre valve must be at the bottom. First place the cover against the rim at the valve side, then hold it in this position with the foot and press it up with both hands.

Have the flat tyre repaired and the wheel balanced as soon as possible.

**Tyre repairs** should always be entrusted to a BMW service station or specialist tyre dealer capable of examining the tyre to determine the full extent of possibly concealed damage.

**Important:** when removing or renewing tubeless tyres, the rubber valve must always be renewed as well as a safety precaution.

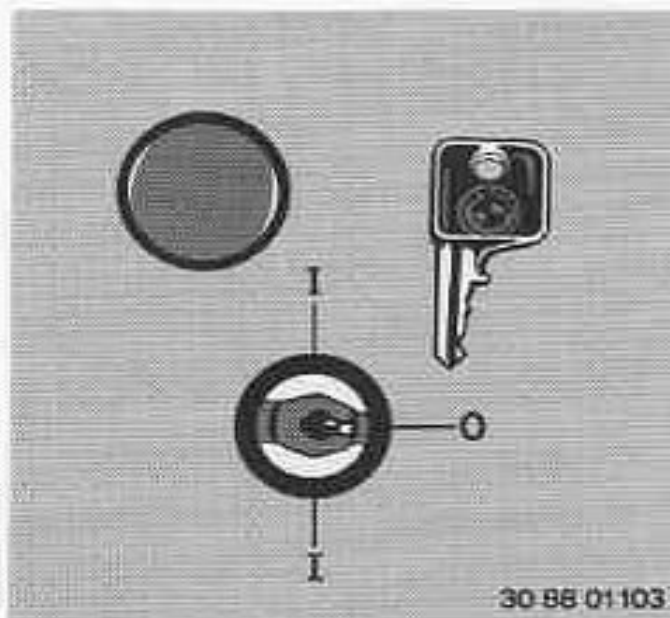

### **Lockable wheel studs**

Take off the end cap, using the edge of the key if necessary.

Insert the key in the lock, turn it app. 90° in either direction and lift off the lock.

O = Locked  
I = Unlocked

Fit the lock by following the same procedure, but in the reverse sequence. Hold the lock tight when pulling out the key.

**Recommendation:** to ensure that the lockable wheel studs can always be removed when necessary (in the workshop, for example), keep a key in the car's toolkit.

### **Brake system**

If the warning light for the brake hydraulics comes on (**LOW BRAKE FLUID** Check Control display):

- loss of brake fluid is indicated by increased brake pedal travel.

#### **Failure of one brake circuit**

Pedal travel will increase and greater pedal effort will be needed.

The car can still be braked satisfactorily with only one circuit in operation.

As for all brake system faults, the car should be taken to a BMW service station for immediate repair.

**BRAKE LININGS** warning in Check Control:

- brake pads worn/renew without delay.

**Important:** use only brake linings approved by BMW, or else the car's general operating permit will be rendered invalid.

### **Power steering**

If the steering becomes stiff, check the oil level (see Page 64).

If the steering is stiff only when the wheel is turned quickly, the V-belt is slack or faulty. Have it retensioned or renewed.

If these measures prove ineffective, consult a BMW service station.

### **Cars with Servotronic:**

If steering becomes increasingly light in action at high road speeds, there is a malfunction in the electronic control system.

**Warning:** If the power assistance fails, a greater force than usual must be applied at the steering wheel to steer the car.

### **BMW 524 td**

#### **Warning light for water in fuel comes on:**

Empty the water trap in the fuel filter at the next opportunity. To do this, slacken off the breather screw on the fuel filter head and press the valve upwards at the filter (base) until diesel fuel flows out.

To keep the engine compartment clean and avoid pollution, collect seepage in an appropriate container.

#### **Warning light for electronic fuel injection system control comes on:**

There is a fault in the electronic fuel injection system.

Unless the engine fails to run at all, the car can continue to be driven with the aid of a stored emergency-running program, although output may be somewhat lower. However, you should have the fault repaired by a BMW service station as soon as possible.

#### **Start readiness telltale fails to come on:**

One or more preheater plugs are faulty. The engine can still be started, but only with some difficulty.

Have the fault repaired immediately by a BMW service station.

#### **If the preheating telltale flashes:**

**Switch off the engine straight away** and disconnect the negative battery lead.

Refer to a BMW service station.

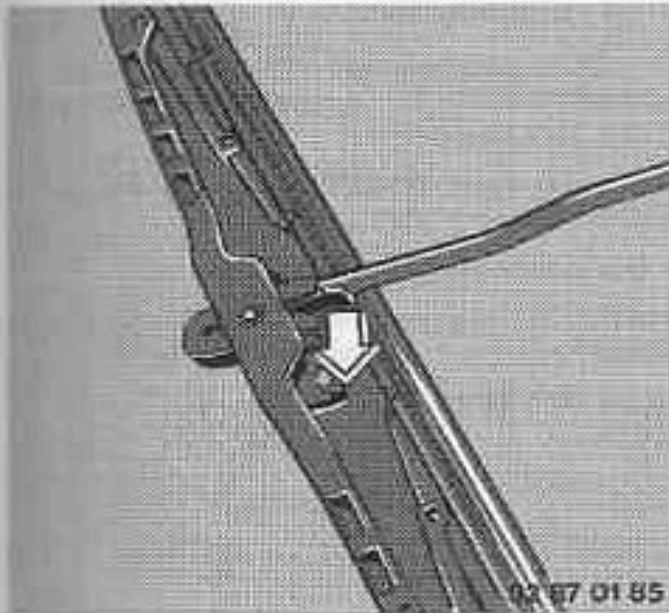

### **Windscreen wipers**

Renewing a wiper blade:

Pull the retaining spring (arrow) and pull the blade off towards the wiper arm.

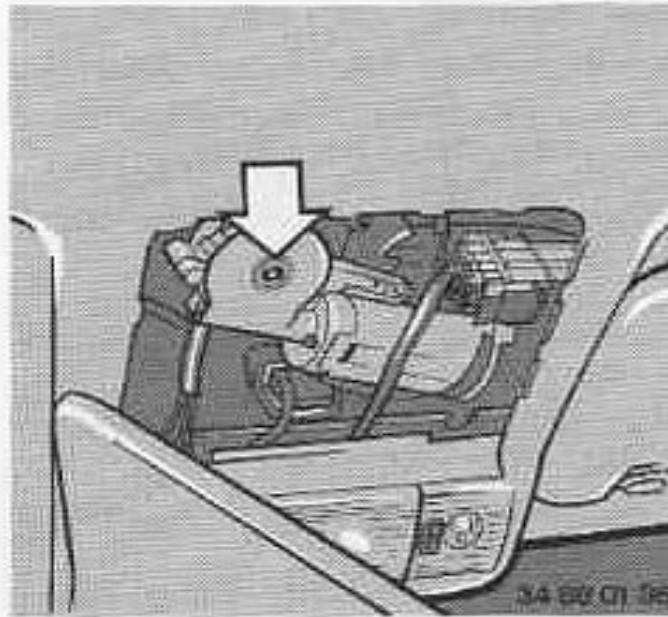

### **Sliding/vent roof**

Mechanical operation in the event of electrical failure:

Remove the cover. Insert and turn an Allen key (in toolkit) to move the sunroof panel in the desired direction.

Have the fault repaired without delay by a BMW service station.

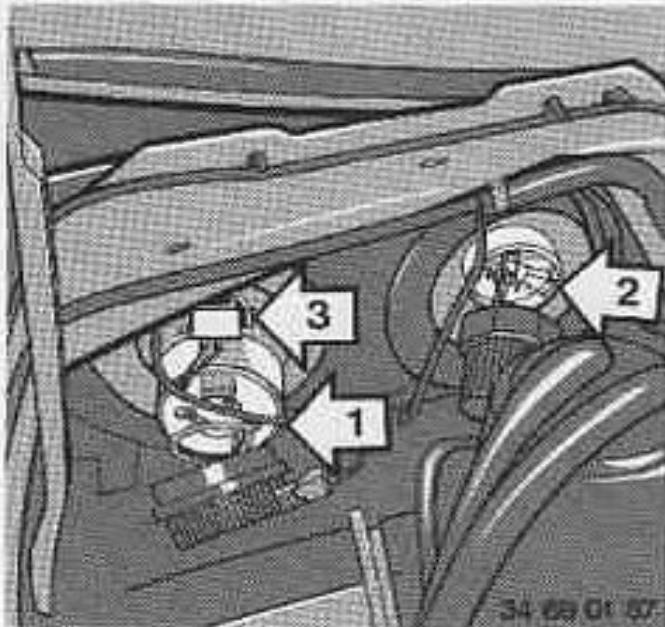

### Changing bulbs

When performing any work on the car's electrical system, always switch off the item concerned or disconnect the battery negative lead to avoid the risk of short-circuits.

Do not hold new bulbs with bare fingers. Use a clean cloth, paper towel or similar, and only hold the base of the bulb.

A box of spare bulbs for emergency use is available from BMW service stations.

### Low beam headlights (1)

55 Watt H1 halogen bulb

Open the engine compartment lid, turn the plastic cap to the left and pull it off the rear of the headlight unit.

Release the wire spring clip, pull the plug off the bulb and renew the bulb.

### High beam headlights (2)

55 Watt H1 halogen bulb

Same bulb-changing procedure as low beam headlights.

To prevent water entering through loose outer covers, make sure that all three pins of the bayonet catch engage when attaching the covers.

### Parking and side lights (3)

5 Watt bulb.

Press the bulb holder in slightly and turn it to the left to remove. Pull out the bulb.

### Automatic headlight beam throw adjustment

If the low beams terminate exceptionally close to the car, this indicates a defect.

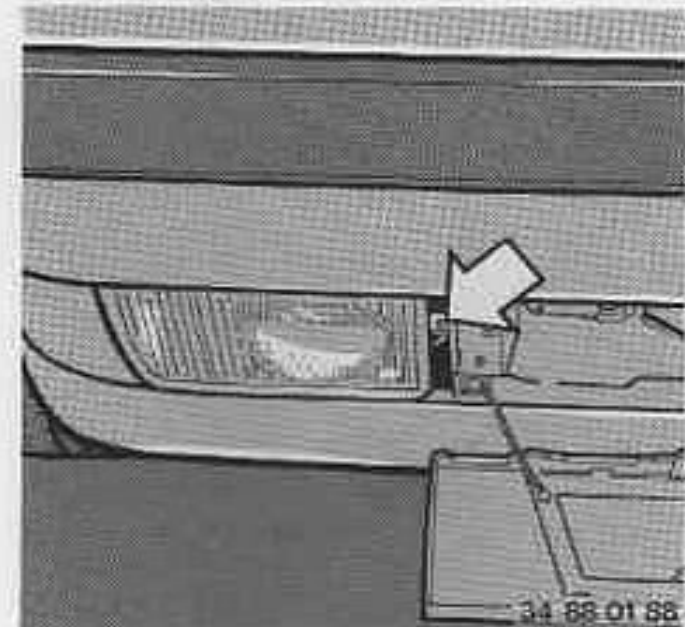

### Front fog lights

55 Watt H1 halogen bulb.

Pull off the cover next to the headlight, remove the Phillips-head screw (arrow) and swing the light assembly out. Turn the cover to the left and remove it from the back of the light. Release the wire spring clip and renew the bulb detaching the plug from it.

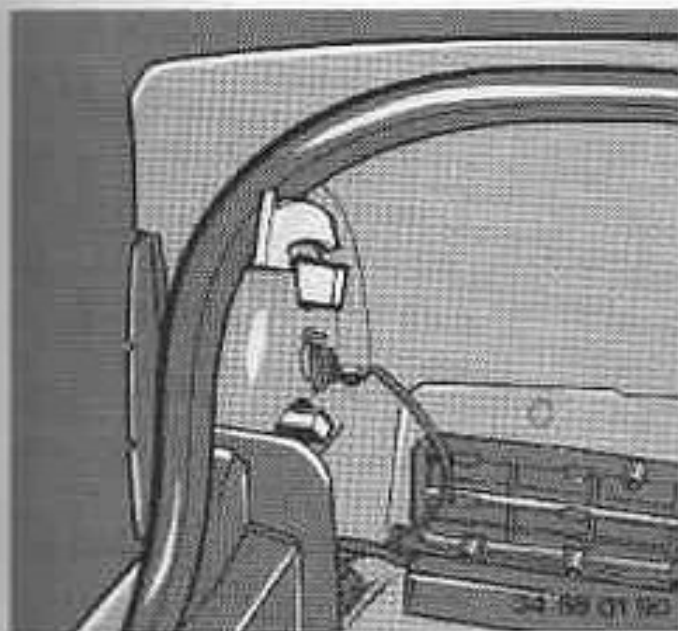

### Rear light cluster

Rear lights: 5 Watt bulb.  
Other lights: 21 Watt bulb.

### Lights in rear bulkhead:

Lift up the luggage compartment floor mat and take off the rear-panel trim after opening the quick-release fasteners.

Gently press in the holder of the affected bulb and turn it to the left to remove. Remove the bulb from the holder in the same way.



### Lights in luggage compartment lid:

Lift up the trim sufficiently, gently press in the holder of the affected bulb and turn it to the left to remove. Remove the bulb from the holder in the same way.

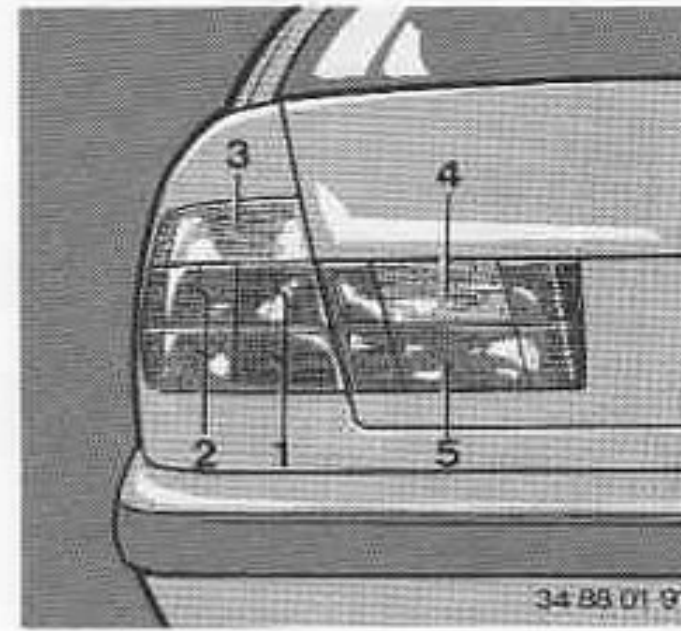

- |                              |          |
|------------------------------|----------|
| 1 - Rear light and reflector | (red)    |
| 2 - Brake light              | (red)    |
| 3 - Turn indicator           | (yellow) |
| 4 - Reversing light          | (white)  |
| 5 - Rear fog light           | (red)    |



### **Front turn indicators**

21 Watt bulb.

Squeeze the bulb holder tabs gently together and pull out the bulb holder. Press the bulb in gently and turn to the left to remove from the holder.

### **Side turn indicators\***

5 Watt bulb.

Remove the Phillips-head screw and push the housing forwards out of the side panel. Turn the bulb gently to the left to remove.

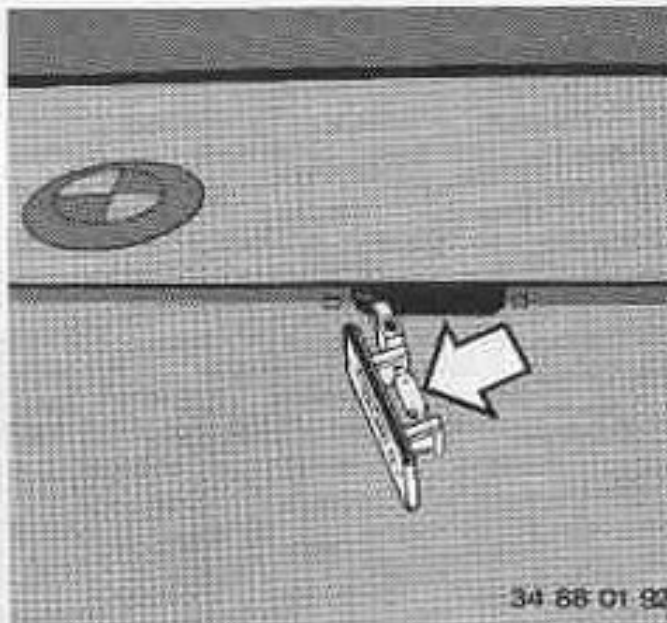

### **Licence plate light**

5 Watt bulb.

Remove the Phillips-head screws and take off the lens frame with rubber seal. Pull the bulb out of the contact blades.

### **Interior lights**

Front: 10 Watt bulbs.

In conjunction with reading lights:

Interior light: 15 Watt bulb

Reading lights: 10 Watt bulbs

Pull out the light, swing back the reflector and renew the bulb. Reading lights: press the bulb in slightly and turn to the left to remove.

Rear: 10 Watt bulbs.

Pull out the light, take off the reflector and renew the bulb.

Reading lights: press the bulb in slightly and turn to the left to remove.

### **Luggage compartment lights**

10 Watt bulbs.

Light on underside of rear shelf:

Lever out light by inserting a screwdriver in the recess, and renew the bulb.

Lights in luggage compartment lid: pull off the glass and change the bulb.

### **Engine compartment light**

10 Watt bulb.

Press the clip away from the glass with a screwdriver, take off the glass and renew the bulb.

## Laying up out of use

If the car is to be laid up out of use for **more than three months**, we recommend that the following maintenance work be carried out by a BMW service station to prevent deterioration during the storage period.

1. Clean and apply protective or preservative treatment to the engine, engine compartment, underbody, axles and other mechanical assemblies in accordance with BMW factory instructions. Wash the body, clean the interior and clean or protect the paintwork and chromium-plated parts as necessary. Clean rubber seals on doors and lids, and rub them with talc or glycerin.
2. Change the engine oil and renew the filter element while the engine is at normal operating temperature. As an additional anti-corrosion measure, a corrosion inhibitor can be added to the engine oil in accordance with the supplier's instructions.
3. Check coolant level and concentration, and correct if necessary.
4. Check acid level in the battery cells and top up with distilled water if necessary.
5. Drain the windscreen washer fluid tank and lines.
6. The fuel tank should be filled to prevent corrosion caused by moisture condensate.
7. Increase tyre pressures to 4 bar (app. 57 lb/in<sup>2</sup>).

Drive the car immediately before it is to be taken out of use and apply the foot brake and the handbrake until sufficient heat is generated to dry out the brake pads and linings and ensure that the brake discs and drums cannot corrode.

Store the car in a dry, well-ventilated place. Select reverse gear (P on cars with automatic transmission). Do not apply the handbrake; if necessary, chock a wheel to prevent the car rolling away.

Disconnect the negative lead from the battery. If there is any risk of frost, remove the battery and store in a warmer place. The battery must be recharged at least every 3 months, or it will become unsuitable for further use.

The air conditioning, if fitted, must be run briefly at least once a month; this is particularly important in the cold season of the year, to prevent the compressor-shaft seals from drying out and allowing refrigerant to leak. The engine should be run for this purpose until it reaches normal operating temperature (coolant temperature gauge needle approximately midway between the two coloured zones). This will prevent condensate from forming, and avoid the risk of internal engine corrosion. If the car is not equipped with air conditioning, do not run the engine during the storage period.

Note that if the car's registration was allowed to lapse or the car was officially taken out of use, the proper legal procedure and the time limits for re-registration must be carefully observed, or else the general operating permit may be invalidated. Comply with your national regulations.

## Restoring car to use

First recharge the battery or renew it if necessary.

An authorised BMW service station should then perform Inspection I, including the Annual Check if necessary.

## Winter operation

The winter months often bring with them severe changes of weather, and you must not only adopt a correspondingly cautious attitude to driving but also take certain precautions to ensure that your car comes through the winter months reliably and without breakdowns.

On winter roads, tyre grip is often very poor, and the driver must remember that braking distances are much greater than usual in many situations.

Before the cold season of the year commences, you are recommended to take your car to a BMW service station for the necessary winter preparations to be carried out.

Comply with the appropriate **engine-oil requirements**, and do not wait until the next scheduled oil change to fill the engine with winter-grade oil if the weather turns cold suddenly.

Apart from checking oil levels, no special winter operating precautions are needed on the manual gearbox/automatic transmission, final drive, power steering, hydraulic brake system or self-levelling suspension.

The coolant already contains a **long-life anti-freeze and corrosion inhibitor**. To ensure full corrosion protection, its concentration must be kept at 40 % all the year round. This provides antifreeze protection down to approx.  $-27^{\circ}\text{C}$  ( $-16.6^{\circ}\text{F}$ ).

Use only factory-approved long-life anti-freeze and corrosion-inhibiting additives. BMW service stations know the approved grades.

Renew the coolant **every 2 years**. Check antifreeze concentration before and during the

cold season of the year. At the same time, inspect the cooling system for leaks and renew any coolant hoses which have become porous or brittle.

Engine temperature is regulated by the coolant thermostat according to engine load and outside temperature. For this reason, no radiator blind or grille blanking-off material should be used.

The engine will not start reliably unless the **battery** is fully charged. Remember that a cold battery is less efficient, yet the demands made on it are more severe than in warm weather.

Use only factory-approved care products\* on the **door locks**, to prevent unreliable operation.

These products also help to prevent the locks from freezing; but if a lock should freeze despite these precautions, the key can be heated before inserting to thaw out the lock.

To prevent **rubber seals** on doors and lids from freezing, treat them with a rubber-care product\* or silicone spray\*.

The car's **paintwork**, as well as **chromium-plated or polished metal parts**, should be protected before and during the winter months by applying suitable bodywork care products\*.

**Have your car's brakes checked regularly before and after each winter driving period by a BMW service station. This work can usually be combined with whatever maintenance routine happens to fall due.**

\* Available from BMW dealers.

## Diesel oil

To ensure reliable operation of the diesel engine during the cold season, make sure that you refuel with "winter-grade" diesel oil, as sold by reputable garages and filling stations during this period. The standard fuel-filter heater prevents the fuel from setting when the car is being driven.

### Outside temperatures below $-15^{\circ}\text{C}$ ( $+5^{\circ}\text{F}$ ):

Additional precautions have to be taken at these very low temperatures.

BMW service stations know the BMW factory-tested and approved brand-name flow improvers for diesel oil.

The fuel's pour point can also be lowered by adding paraffin:

Paraffin:	Winter-grade diesel oil:	Summer-grade diesel oil:
	Pour point:	
50%	app. $-31^{\circ}\text{C}$ (app. $-24^{\circ}\text{F}$ )	app. $-25^{\circ}\text{C}$ (app. $-13^{\circ}\text{F}$ )
30%	app. $-26^{\circ}\text{C}$ (app. $-15^{\circ}\text{F}$ )	app. $-15^{\circ}\text{C}$ (app. $+5^{\circ}\text{F}$ )
10%	app. $-20^{\circ}\text{C}$ (app. $-4^{\circ}\text{F}$ )	app. $-9^{\circ}\text{C}$ (app. $+16^{\circ}\text{F}$ )

In an **emergency**, up to 30 % regular-grade (2-star) fuel (petrol, gasoline) can be added to the diesel oil to prevent paraffin from being precipitated out. However, this measure will have an adverse effect on fuel consumption and driving characteristics.

## Winter tyres

If **winter tyres** (radial-ply tyres with a special winter tread pattern) are fitted, they must, in the interests of good directional stability and steering control, be of the same make and tread pattern **on all four wheels** (and preferably on the spare wheel as well).

You are recommended to fit **only BMW-approved winter tyres**. Any BMW service station will be glad to advise you on selecting the right winter tyres for the anticipated operating conditions.

The speed-rating code letters indicate the maximum permissible road speeds for winter tyres:

- (Q) M + S – up to 160 km/h (100 mile/h)
- (T) M + S – up to 190 km/h (118 mile/h)
- (H) M + S – up to 210 km/h (130 mile/h)

Always comply strictly with the maximum road speeds specified for your winter tyres.

Depending on national regulations, you may be required to display a **notice within the driver's field of view** stating the maximum speed limit for these tyres, if the car is capable of a higher speed. Tyre dealers can supply suitable adhesive labels if they are needed.

When the tyre tread has worn to a depth of less than 4 mm (0.16 in), tyres become much less effective in winter, and should then be renewed as a safety precaution.

Always keep to the specified **tyre pressures** and have the wheels rebalanced whenever you change a tyre or a wheel.

**In cold weather, we recommend carrying the following items** in case of emergency:

A quantity of **sand** to aid starting on ice-covered slopes.

A **shovel** to dig the car out of snowdrifts.

A **plank** to act as a support for the car's jack.

A **brush and ice scraper** to clear the windows and body panels if covered with snow or ice.

**BMW snow chains** for all severe winter driving conditions. Snow chains are available for all BMW-approved tyre sizes and can be used on winter and summer tyres, but only in pairs and on the driven (rear) wheels.

The **maximum permitted speed** should not be exceeded (for example 50 km/h (31 mile/h) in the Federal Republic of Germany). Always comply with the local speed regulations of the country in which you are driving.

Any BMW service station will be pleased to provide further details.

## Winter driving hints

When planning a fairly long journey in winter, allow plenty of time in case severe weather conditions and bad roads are encountered. Local newspapers, radio and TV, the telephone service and the automobile clubs provide information on local road conditions, and also whether certain mountain passes are open to traffic.

**Before starting the journey**, remove ice and snow from the windows, outside mirrors and lights. After a heavy fall of snow, clear the roof and the engine and luggage compartment lids as well. Clear snow away from the entry grilles for the heating/ventilation system in front of the windscreen, so that the airflow is not impeded.

Before getting into the car, try to remove slush, snow and ice from your shoes to avoid the risk of slipping off the pedals.

Driving in ski boots is definitely not recommended, as it is difficult to operate the pedals with a sufficient degree of sensitivity.

**After starting a cold engine**, particularly at temperatures below  $-15^{\circ}\text{C}$  ( $+5^{\circ}\text{F}$ ), the gear lever may be stiff and the car's suspensions may not respond smoothly for the first few minutes of the journey, and other items of equipment may be noisier than usual. This is unavoidable while the oil is still cold and viscous.

When **driving on a slippery surface**, operate the accelerator pedal slowly and smoothly, and avoid high engine speeds by selecting a higher gear quite early. Keep a particularly generous safety margin between your car and the vehicle in front. Select the next-lower gear in good time before reaching an uphill or downhill gradient.

**To improve starting** on icy or snow-covered roads and in hilly country when the car is only lightly laden, 30 – 50 kg (66 – 110 lb) of ballast can be carried in the luggage compartment. Make sure that the ballast is firmly secured and cannot slip.

**If the car slides**, ease back the accelerator and disengage the clutch by pressing the clutch pedal down; on automatic-transmission cars, push the selector lever to N. Try to steer into the skid and get the car back under control in this way.

When **braking**, especially on downhill inclines, avoid causing the wheels to lock so that the car can still be steered. Should the wheels still lock, reduce pressure on the brake pedal until the wheels are just rotating but are still braked. Then increase pedal pressure again until the wheels lock, release

it again etc. Repeat this "cadence braking" sequence as often as possible: it shortens total braking distance and the car remains steerable, so that you have a chance of driving round an obstruction with which you might otherwise collide.

If the car is fitted with an antilock brake system, the braking intervals are regulated electronically without the driver's involvement.

**Note:** when braking heavily on a slippery surface or one providing markedly varying amounts of grip, always declutch.

If the car is immobilised in deep snow, sand or soft ground, pack some firmer material under the rear wheels to provide extra grip before the car digs itself in too far. If nothing else is available, use the car's floor mats. Obtain help if possible to push the car back on to a firm surface. With a degree of skill, the car can be "rocked" out of the holes: use a light throttle opening and select a forward gear and reverse in quick succession, and accelerate only when the car is moving in the desired direction. Avoid wheelspin, however, or the car will sink in deeper still. The handbrake can be applied lightly to prevent one rear wheel from spinning.

**Snow chains** are permitted only in pairs on the driven (rear) wheels. If available, fit them in good time. They increase driving safety on snow and ice, enable the car to climb hills without slipping and reduce braking distances.

However, the driver must become accustomed to the car's changed handling characteristics. Remove the snow chains as soon as possible, as they wear out very rapidly on clear roads.

During a break in the journey or when filling the tank, remove **built-up snow and ice from inside the wheel arches**, to ensure that steering and suspension movements are not impeded.

When **parking** your car, prevent it from rolling away by selecting 1st gear or reverse as appropriate, or P on the automatic transmission. Apply the handbrake if parked on a slope. To prevent the handbrake linings from freezing to the drums in cold weather and to avoid corrosion, apply the handbrake to bring the car to a standstill from slow speed, so that the linings and drums are dried by the heat thus generated.

### **Useful information on disc brakes**

A disc brake system offers optimum braking efficiency, smooth response and high load capacity. The high temperatures which occur during brake applications, for instance when driving hard in hilly areas, necessitate maximum cooling; this is provided by ram air and by the speed of rotation of the brake disc. Severe loads on the brakes affect the temperature of the brake fluid and the pads; overheating may reduce braking efficiency or cause "fading", increased pedal travel and possibly the need for greater effort to be applied at the pedal. However, the boiling point of modern brake fluids is so high that only exceptionally severe use of the brakes amounting to carelessness on the driver's part should cause such situations to arise.

Wet conditions, dirt, salt spread on the roads in winter and brake disc corrosion can impair braking performance by increasing braking distances, altering the car's normal brake force distribution or causing variations in the coefficient of friction at the various wheels, so that the car pulls to one side.

Brake disc corrosion is accelerated if the car is used very little or is garaged for long periods.

Gentle or moderate use of the brakes, although in itself not undesirable, can encourage brake disc corrosion and allow the pads to become dirty, since the minimum pressure

needed for the disc brake's self-cleaning action is not attained between pad and disc.

Corroded brake discs may result in a knocking effect when the brakes are applied; this cannot always be eliminated by prolonged braking.

On the other hand, slight corrosion and surface roughness can be removed by fitting brake pads with an abrasive corundum coating. Any BMW dealer can provide information on braking during the running-in period, use of these brake pads etc.

Dirt burnt into the brake pads (glazing of rubbed area) and clogged drain grooves lead to scoring of the brake discs and also a change, reduction or delay in braking effect.

Another problem in this connection is brake squeal, which tends to increase in intensity as the discs become dirtier or more glazed.

All these **climatic and environmental effects cause a change in the brakes' coefficient of friction**, that is to say less braking efficiency is available for a given pedal effort. If the coefficient of friction changes differently at the various brakes, the car may respond unevenly or pull to one side.

### **Recommended driving procedure for disc brakes**

At intervals when traffic conditions allow, disc brakes should be applied quite hard once or twice from high speed. The resulting high braking pressure ensures that the brake pads and discs are kept clean.

Similarly, on long journeys in poor weather conditions, particularly in winter if salt has been spread on the roads, it is advisable to apply the brakes firmly from time to time when it is safe to do so. This not only tests their efficiency in the prevailing conditions (but take care at temperatures around freezing point!), but also results in a self-cleaning action to ensure that they are ready to operate efficiently even in the worst possible weather conditions.

In wet weather and when rain is actually falling, it is advisable to apply the brakes briefly at light pedal pressure at relatively frequent intervals during the journey. The heat generated in this way keeps the discs and pads dry for a certain period.

Before parking the car after driving through rain, and particularly if salt has been spread on the roads, lightly brake the car to a standstill so that the brake discs are dried and cannot corrode so easily.

If the brake discs already show signs of corrosion, the problem can be cured in its early stages by applying the brakes hard several times. Take care not to endanger other road users, and avoid locking the wheels.

The most effective braking action is always achieved not with locked wheels, but when the wheels are still just turning, the result obtained by the antilock braking system.

Locking the wheels can be dangerous, as locked front wheels can no longer be steered, and locked rear wheels cause the car to skid sideways or spin.

If the brake pads are severely corroded or the pads are very dirty (glazing of rubbed surfaces, clogged drain grooves), they must be examined, cleaned, reconditioned or renewed by a BMW service station.

Even long, steep downhill gradients in the mountains need not adversely affect the action of the brakes if you select the correct gear ratio or automatic-transmission speed range to keep braking operations to a minimum. The engine braking effect is higher in the lower gears; in extreme cases, shift right down to 1st gear or selector lever position 1.

If the engine braking effect is still not sufficient to prevent the car from descending a hill faster than intended, it is wrong to apply the brakes continuously at light or medium pedal load. Instead, brake the car to a safe speed using quite high pedal pressure (but with due consideration for following traffic), then apply the brakes again at intervals to keep the speed down. The cooling phases between brake applications help to avoid overheating and the risk of brake fade.

**Never drive with the clutch pedal depressed, the gear lever or automatic transmission selector in neutral or – still more dangerous – with the engine switched off at the ignition. In neutral, engine braking is entirely lost, and if the engine is switched off the brake booster servo is no longer able to reduce pedal pressure in the normal way.**

### ***What you should know about tyres***

The factory-approved radial-ply tyres have been chosen to suit your car and provide both optimum road safety and the desired level of ride comfort.

The condition of the tyres and maintenance of the specified tyre pressure are vital factors affecting tyre life and also road safety to a very considerable degree.

#### **Tyre treads and tyre damage**

Check the tyres frequently for damage, trapped stones and nails, excessive wear and tread depth.

The **tread depth** is regarded as acceptable in many countries when worn down to as little as 1 mm (0.04 in), but it is advisable to renew tyres when the tread depth is 3 mm (0.12 in). Below this depth there is a serious risk of aquaplaning at even moderately high speeds and when the roads do not seem particularly wet.

If the tyres wear down to 1.6 mm (0.063 in) tread depth, wear indicators become visible at the base of the tread pattern as a reminder that the legal wear limit is approaching.

Tyres must never have their treads recut, in view of the risk of damaging the tyre carcass.

Any **foreign body** (nail or similar sharp object) penetrating the tyre may cause a slow puncture, which will only be detected if tyre pressure are checked regularly. In this event the tyre should be checked and either repaired or renewed as soon as possible by a BMW service station or a specialised tyre fitting dealer.

Drive at moderate speeds over poor road surfaces and approach unavoidable obstructions such as a kerb or a severe bump in the road with care, so that the inner carcass of the tyre does not suffer damage which is invisible externally.

Take care not to bump the **tyre sidewalls** when parking or driving on to loading ramps, car hoists etc.

**Avoid overloading** your car, particularly on holiday trips. Overloading can exceed the tyres' permitted load capacities and cause premature or subsequent damage.

Tyre damage can be extremely dangerous, both for the car's occupants and for other road users.

#### **Fitting new tyres**

To ensure good road behaviour, only tyres of the same make and tread pattern should be fitted to all the car's wheels. Retreaded tyres are not approved, since their carcasses may differ in construction or degree of ageing, with a possibly detrimental effect on subsequent operating life and, in certain cases, on the car's handling and safety.

#### **Changing wheels round**

In the interests of safety and of optimum working conditions in conjunction with the chassis and suspension, we recommend that the wheels should not be interchanged.

### **Road wheels and tyres**

You are recommended to use only tyres approved by BMW. On models with a top speed in excess of 220 km/h (137 mile/h), certain makes and sizes of tyre are compulsory. Details are available from any BMW service station.

Observe all relevant national legislation concerning tyres.

The speed rating codes indicate the maximum permissible road speeds for summer tyres (subject to legal limits):

S	= up to 180 km/h (112 mile/h)
T	= up to 190 km/h (118 mile/h)
H	= up to 210 km/h (130 mile/h)
V	= up to 240 km/h (149 mile/h)
VR	= over 210 km/h (130 mile/h)
ZR	= over 240 km/h (149 mile/h)

The tyre valves are provided with **screw dust caps** to keep out dirt. If dirt enters a valve, a slow leak may result.

**Approved BMW road-wheel and tyre sizes:**

Radial-ply tyre (tubeless)	Pressed-steel wheel	Light-alloy wheel	Offset mm (in)
<b>BMW 520i, 524td</b>			mm
195/65 R 15 91 H	6 J x 15 H2 6½ J x 15 H2		20 (0.79) 20 (0.79)
205/65 R 15 94 H 225/60 R 15 95 H	6½ J x 15 H2	7 J x 15 H2	20 (0.79)
TD 230/55 R 390 94 H		390 x 180 TD	19 (0.75)
240/45 R 415 94 H		195 TR 415	19 (0.75)
200/60 R 390 90 H M + S 220/55 R 390 93 H M + S	165 TR 390	165 TR 390	22 (0.87)
<b>BMW 525i</b>			
195/65 VR 15 195/65 R 15 91 V	6½ J x 15 H2		20 (0.79)
205/65 VR 15 205/65 R 15 94 V	6½ J x 15 H2	7 J x 15 H2	20 (0.79)
225/60 VR 15 225/60 R 15 95 V	6½ J x 15 H2	7 J x 15 H2	20 (0.79)
TD 230/55 VR 390 TD 230/55 R 390 94 V		390 x 180 TD	19 (0.75)
240/45 VR 415 240/45 R 415 94 V		195 TR 415	19 (0.75)
200/60 R 390 90 H M + S 220/55 R 390 93 H M + S	165 TR 390	165 TR 390	22 (0.87)

**Winter tyres**

The same road wheel/tyre combinations are permitted as for summer tyres, except where shown.

The use of **fine-link BMW snow chains** with summer and winter tyres is permitted only in pairs, that is to say on both driven (rear) wheels.

**Snow chains cannot be fitted** on the combination of 240/45 R/VR/ZR 415 types on 195 TR 415 rims.

**Approved BMW road-wheel and tyre sizes:**

Radial-ply tyre (tubeless)	Pressed-steel wheel	Light-alloy wheel	Offset mm (in)
<b>BMW 530i</b>			mm
205/65 VR 15 205/65 R 15 94 V	6½ J × 15 H2	7 J × 15 H2	20 (0.79)
225/60 VR 15 225/60 R 15 95 V	6½ J × 15 H2	7 J × 15 H2	20 (0.79)
TD 230/55 VR 390 TD 230/55 R 390 94 V		390 × 180 TD	19 (0.75)
240/45 VR 415 240/45 R 415 94 V		195 TR 415	19 (0.75)
220/55 R 390 93 H M + S	165 TR 390	165 TR 390	22 (0.87)
<b>BMW 535i</b>			
205/65 R 15 93 Q/T/H M + S	6½ J × 15 H2	7 J × 15 H2	20 (0.79)
225/60 VR/ZR 15 225/60 R 15 95 Q/T/H M + S	6½ J × 15 H2	7 J × 15 H2* 7 J × 15 H2	20 (0.79) 20 (0.79)
TD 230/55 VR/ZR 390		390 × 180 TD	19 (0.75)
240/45 VR/ZR 415		195 TR 415	19 (0.75)
220/55 R 390 93 H M + S	165 TR 390	165 TR 390	22 (0.87)

\* When fitting summer tyres, it is essential to use the correct version of pressed-steel wheels, as otherwise there is a risk of the brakes overheating. Consult a BMW service station for advice if in doubt.

Please note the wheel/tyre specifications in the car's registration documents. Use of deviating wheel/tyre dimensions approved by BMW may necessitate an official entry in the car's registration documents.

**Technical modifications to the car**

Any BMW service station will advise you on the practical value, legal position and factory attitude before modifications are undertaken; please quote the vehicle identification number and, where appropriate, the engine number.

**Note:** certain items on this car may contain asbestos. Spare parts are marked accordingly.

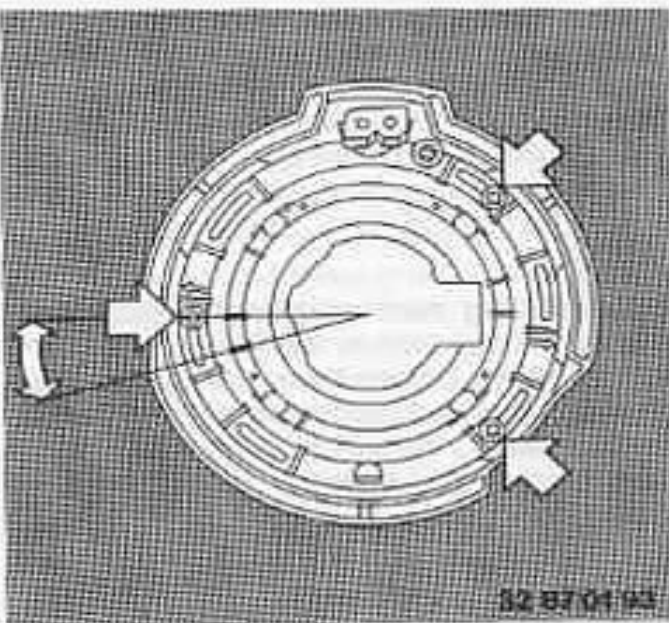

### **Adjusting headlight beam setting for countries where traffic drives on the opposite side of the road**

When crossing a border into a country with a different "rule of the road", that is to say where traffic drives on the opposite side of the road:

- slacken off the 3 Phillips-head screws on the rear of the dipped (low) beam headlights
- turn the headlight unit round in the slots to the opposite limit of its travel
- re-tighten the screws.

If required, a BMW service station will carry out this work for you.

### **Re-registration abroad**

Each car is supplied in accordance with the road vehicle use regulations of the country for which it is intended.

If the owner moves abroad and wishes to re-register the car locally, information should be obtained well in advance as to possible import and licensing restrictions or differences in the legal position.

The Service Division of BMW AG, German telephone number (0)89-32380, will endeavour to supply this information if you quote the model, vehicle identification number and date first registered.

### **Roof rack**

A loaded roof rack can seriously affect the handling and steering characteristics of the car by displacing its centre of gravity. Luggage racks may also damage the car's bodywork. When loading items on to a roof rack, make sure that the permitted roof load, gross weight and axle loads are not exceeded.

To ensure the lowest possible roof load and optimum drag coefficient, use only a BMW-approved luggage or ski rack. When installing a roof rack, make sure that the mountains are attached securely to the roof and are located as far apart as possible.

The roof load must be evenly distributed and not too large in surface area. Always stow the heaviest items at the bottom.

Make sure that luggage on the roof is secured tightly and in the correct manner, so that there is no danger of it shifting or even falling off and endangering other road users during the journey.

Drive smoothly, avoiding jerky starts and sharp braking, and do not corner too fast. Luggage on the roof increases the car's frontal area, so that fuel consumption suffers and the load on the car's roof panel is increased.

You are recommended to remove the roof rack whenever it is not needed.

Note and comply with national regulations when loading your car.

## Towing a trailer

Driving with a trailer always imposes more severe demands on both car and driver.

The trailer not only makes the car less manoeuvrable, but also affects its ability to climb hills and its acceleration, braking, ride and cornering behaviour.

The **trailer load limit** and the **towbar downthrust** or nose weight are shown in the section headed "Technical data"; the trailer load limit may also be stated in the car's licensing documents.

Towbar downthrust or nose weight is the vertical force exerted by the trailer on the ball hitch attached to the towing vehicle, and can be measured with the aid of bathroom scales.

In the Federal Republic of Germany, for instance, a minimum nose weight of 25 kg (55 lb) is laid down by law.

Without exceeding the limit, try to make full use of the maximum permissible nose weight if possible.

When **loading the trailer**, remember that keeping the trailer's centre of gravity low greatly increases the safety of the complete outfit when on the move.

The gross trailer weight limit, the trailer axle load limit and the car's rear-axle load limit must all be complied with; note that the limit is represented by whichever of these values is reached first.

The trailer coupling or towing hitch, with detachable ball head, should be of a pattern tested and approved by BMW; like the **trailer flashing turn indicator telltale** (required by law in certain countries including the Federal Republic of Germany), it should be correctly installed by a BMW service station.

After removing the detachable ball-ended towbar, it should be kept greased so that it can be installed again without difficulty.

Before acquiring a trailer it is advisable to obtain confirmation from the manufacturer or supplier of the **effective trailer weight** and the **permitted payload**.

The **suspension rates** of your BMW (both standard and sports suspension) ensure an optimum combination of road safety, ride comfort and good roadholding for the enthusiastic driver. They are equally suitable for towing a trailer at the standard trailer load limit, provided that this takes place only occasionally, culminating perhaps in one major holiday trip per year, and on the assumption that the driver is prepared to modify his approach to allow for the more arduous task of trailer towing.

**Sports suspension** is stiffer all round, and is intended for the enthusiastic BMW driver who tows a trailer occasionally, at the standard trailer load limit.

If the car is to be used very frequently with a trailer, you are recommended to specify the following items, provided that they are designed to fit your particular model: uprated suspension for trailer towing or self-levelling rear suspension.

**Trailer-towing suspension rates** are stiffer at the rear axle, so that the tail of the car rides slightly higher than usual when driving without a load or trailer. They are recommended for frequent trailer towing, but are less suitable for normal driving since the centre of gravity is raised and the axle data are changed.

**Self-levelling rear suspension** (automatic ride-height control) is the ideal solution for trailer towing. Unless the rear axle load is exceeded, the car always returns to its designed static ride height regardless of the load carried and whether the trailer is attached or not.

BMW has not tested or approved any other suspension devices sold by the automotive accessory trade.

The installation of a stabilising device is recommended, particularly with heavy trailers. BMW service stations can provide details.

If the standard **door mirror** is inadequate with the trailer attached, the law requires two outside mirrors to be fitted which enable the driver to see both rear corners of the trailer. Your BMW dealer can supply suitable mirrors, including types with adjustable arms or detachable version for driving without the trailer.

The **maximum gradient** laid down for your car is restricted, in the interests of unobstructed traffic flow and maximum road safety, to 12 % (1 in 8.3) or, with trailers of greater weight, to 8 % (1 in 12.5).

Remember that the effect of the trailer brakes may be relatively limited, particularly when descending steep gradients. Select the next-lower gear in good time, and shift down as far as first gear (or automatic transmission speed range) if necessary to keep the outfit's speed low. Operate the foot brake only for limited periods at a time, to prevent fade.

Before starting a journey on which steep gradients are likely to be encountered, the serviceability of the trailer brakes should always be checked by an authorised service station.

The ABS will prevent the wheels from locking (vehicles fitted with ABS). We therefore recommend brake applications in situations where the ABS will respond. Smooth, steady brake applications will yield the shortest stopping distances for the car-trailer combination, particularly on low-friction surfaces (icy roads).

The **maximum speed limit** when towing a trailer in the Federal Republic of Germany is 80 km/h (50 mile/h) on all roads. Even if higher speed limits are authorised in some countries, you are still recommended not to exceed 80 km/h (50 mile/h) for safety reasons.

Correct **tyre pressures** are of particular importance.

For the trailer, comply with the manufacturer's recommended tyre pressures.

Always check operations of the **trailer's rear lights** before starting the journey.

## **Antilock brake system (ABS)**

BMW's unceasing efforts to improve its cars' active safety still further have led to the development of an antilock brake system (ABS).

Whenever a brake application is made, the ABS is required to satisfy two fundamental requirements:

- a) To maintain the car's stability on varying surfaces (asphalt, concrete, mud, wet roads, snow and ice)
- b) To ensure that the car can be steered and manoeuvred in these adverse conditions.

These requirements must, however, be seen in the light of certain unavoidable accompanying factors.

Even ABS is unable to prevent the natural laws of physics and motion from acting on the car. For instance, it cannot avoid the consequences of braking when there is insufficient distance remaining from the car in front, when cornering limit speeds are exceeded or if there is a risk of aquaplaning (tyres riding up on a cushion of surface water). It remains the driver's task to judge speeds and brake applications correctly in such conditions.\*

The fact that a car is equipped with ABS must never tempt the driver into taking risks which could affect occupant safety and that of other road users, despite the increased safety margins this system frequently provides.

### **Driving a car equipped with ABS**

After the engine has been started, the yellow **ABS warning light** on the instrument panel will go out.

The system itself is then in working order, but does not come into action until road speed exceeds approx. 8 km/h (5 mile/h). After this minimum control speed limit has been reached, the ABS prevents the wheels from locking when the driver applies the brakes. If the speed drops again below approx. 3 km/h (2 mile/h), the ABS ceases to operate, so that in theory the wheels could lock at the very end of a brake application, though in practice this is not critical at such a slow speed. The ABS regulating cycle is performed repeatedly within fractions of a second.

To inform the driver that his brake application has caused the ABS to come into action, a pulsating effect is noticed at the brake pedal, together with a characteristic chattering noise. This acts as a warning that grip between the tyre and the road is being lost (slippery surfaces), so that the driver can reduce speed accordingly.

ABS is capable of achieving the shortest possible braking distances in any given conditions (straight-line running or cornering, on smooth asphalt, ice, wet surface etc.).

The braking distance may be slightly longer on loose surfaces covering a firm base, such as snow or gravel, or if snow chains are fitted, since the locked wheels of a conventionally-braked car tend to build up a wedge of the loose material as they are forced through it.

However, the benefits of greater stability and the fact that the car can be steered more than outweigh this occasional slight drawback.

The ABS control unit incorporates an electronic fail-safe monitoring system which checks that all components are in working order before each journey, and repeats this check regularly when the car is in motion. The yellow ABS warning light on the instrument panel comes on to indicate any malfunction. The brake system then operates conventionally and with precisely the same standards of performance as on cars not equipped with ABS.

### **Automatic Stability Control (ASC)**

As a means of ensuring improved dynamic stability, particularly when accelerating and cornering, BMW has extended its ABS system to include ASC, which prevents the driven wheels from spinning even if driving and road conditions are unfavourable.

The traction and vehicle locating force which the tyres can transmit to the road surface depend to a marked degree on driving style (use of the engine's power potential) and road surface condition (wet, slippery etc.). The limits imposed by the factors should not be exceeded, or else the car may become difficult to keep under control.

ASC is a highly responsive system which uses the ABS wheel sensors to detect wheel rotating speeds, and reduces engine power if these speeds differ.

This continuous wheelslip monitoring system identifies the risk of a wheel spinning if it is called upon to transmit too much power, and reduces engine power output until reliable tyre grip is assured.

Although the driver may find this automatic reduction of engine power difficult to accept, there is no denying that when a difficult situation arises (poor road surface, sharp corner etc.), the instant response of the ASC system is the only way of ensuring optimum traction and acceleration.

However, even a car fitted with ASC is subject to the normal physical laws, so that the driver must still avoid speeds at which tyre grip cannot be maintained or lateral forces become too high. It would be irresponsible to misuse the additional safety margin which ASC can provide in certain circumstances to drive at the very limit of the car's performance when this would constitute a self-evident safety risk.

The ASC system can be switched off and the car's driveline allowed to operate conventionally. It is also advisable to switch it off when trying to rock the car out of deep snow or a soft surface (see "Winter operation") and when snow chains are fitted.

If not all the tyres are of the same pattern, ASC may react over-sensitively. Only fit tyres of the same make and tread pattern.

### **Multi-disc limited-slip differential**

In very unfavourable driving conditions, the conventional form of differential may be unable to transmit torque to the road without wheelslip occurring. The limited-slip differential (25 % action) greatly reduces the tendency for one driven wheel to spin.

In practice, this means improved traction when pulling away, accelerating and cornering at speed in poor driving conditions.

A car also tends to spin round its vertical axis (centre of gravity) when the power output is high or when load reversals occur on surfaces with a varying degree of grip. A good deal of skill is required to control such skidding or spinning, particularly when driving in a highly enthusiastic manner.

The limited-slip differential has the advantage of operating automatically when needed; it does not have to be engaged and disengaged by the driver.

## Care of the car

The car's high-quality paint finish is chosen not only to appeal to the owner's personal colour preferences, but also to provide maximum body protection. It consists of **several layers** for reliable corrosion-proofing; the body cavities are not only primer-coated by cathaphoretic dipping, but also treated with materials specially developed for this purpose in lengthy tests. The entire floor pan is given a sprayed-on, resilient PVC coating followed by complete wax-based undersealing.

Every 12 months, during the **Annual Check**, have the body including the floor pan examined by a BMW service station. Full details are given in the Service Booklet.

Regular care and maintenance make a big contribution to safety and to your car's resale value.

A large number of **environmental influences** can affect the car's paintwork, some of them purely local in origin. They govern the amount of care the paintwork needs and how often it should be attended to.

**Road dust and dirt**, tar stains, dead insects, animal excretions (high level of alkali formation) as well as tree and plant materials (resin, pollen) all contain chemicals which, if allowed to remain on the car for any length of time, can damage the paintwork by causing patches, blisters, corrosion, flaking of the top coat etc.

In **industrial areas**, the horizontal panels of the body in particular may suffer from deposits of fly ash, lime, oily soot or substances containing sulphur dioxide ("acid rain"), as well as other less easily identified deposits. Only regular care of the paintwork can avoid damage in such circumstances.

In **coastal regions** the high salt content and humidity of the atmosphere greatly increase the risk of body panel corrosion.

In **tropical climates**, ultra-violet radiation from the sun is very strong, the air is often very humid and temperatures can exceed 40° C (104° F) in the shade. Light paint finishes may heat up to 80° C (176° F) and darker colours as high as 120° C (248° F). Prolonged exposure could cause the paint finish to develop cracks, particularly on horizontal surfaces.

In the event of **mechanical damage** caused by sand, road salt, grit etc., the paint surface may be damaged or penetrated, and corrosion may then spread across the panel under the paint.

Since the car's paintwork is exposed to so many potential environmental hazards, automobile manufacturers and paint suppliers are constantly working on further improvements to the strength and durability of modern paints.

The composition of the paints used by BMW and the manner in which they are applied are in accordance with the very latest standards in this specialised area.

**BMW car care can be entrusted to the experts who know what's best for your car: the BMW Service Organisation. But even if you choose to look after the car yourself, BMW service stations can supply you with conveniently-sized packs of all the correct car care products.**

### Care of paintwork

To protect the car from the start against gradual deterioration of the paintwork in areas of high atmospheric pollution or where natural substances could damage the paint finish (industrial zones, railways, sap and resin from trees, pollen, bird droppings), it is advisable to **wash the car once a week**. In severe cases, wash the car whenever the paint finish is seen to be dirty or contaminated.

**Remove** spilled fuel, oil, grease or brake fluid **at once**, as they can attack the paint and change its colour.

Bird droppings should also be **removed without delay**, or they will damage the paintwork.

A new BMW can be put through an automatic car wash, or washed by hand, as soon as it is used on the road.

In automatic car washes, make sure that any projecting body elements (e.g. spoilers) cannot become damaged.

If necessary, point them out to the person in charge of the car wash before using it.

Dead insects should be soaked and wiped off **before** the main car wash.

### Washing the car

Do not wash the car if the engine compartment lid is still hot, or if the car has been standing in strong sunlight, or else patches may form on the paint surface.

When using an **automatic car wash**, try to choose one without excessive brush pressure and with an ample supply of rinsing water. Most modern car washes satisfy these requirements. However, the areas not fully reached by the automatic car wash – door sills, panel folds and seams on doors and lids etc. – should be cleaned by hand.

During the cold season of the year in particular it is advisable for the car to be washed more frequently, since heavy dirt deposits and salt from wet roads are more difficult to remove and will damage the entire car if left on too long.

If the car is **washed by hand**, first soften the dirt deposits on the paint with a fine water spray, and rinse them off. Do not spray water directly into the air inlets or outlets of the heating/ventilation system.

After this, wash the upper part of the body with a sponge, wash leather glove or similar, using plenty of no more than lukewarm water, and starting with the roof. Rinse out the sponge frequently.

Wash the lower part of the body and the wheels last of all, if possible keeping a separate sponge just for these areas.

After washing, rinse the car down again thoroughly with the hose and dry it with a clean chamois leather to prevent discoloured patches where the water was not removed.

To protect the paintwork, a paint-care product\* can be added to the water used for washing the car.

If washing with water alone is insufficient, a car shampoo or similar cleanser\* which restores the fats content of the paintwork can be used, in the concentration stated on the pack. After this, rinse down with plenty of water.

Note: after washing, the car's brakes may be wet and therefore less effective in action. Apply them briefly if the car is driven immediately afterward, to dry the discs.

Any local dirt patches or other contamination of the paint surface can best be seen after the car has been washed. Remove them as soon as possible with a clean cloth or wadding soaked in alcohol spirit or cleaning-grade petrol (gasoline). Eliminate tar stains with a special tar remover\*.

Polish the paintwork at these points to restore its appearance and protect it.

Please use only **paint care products** containing carnauba or synthetic waxes.

It is quite easy to decide when the car's paintwork needs polishing or preservative treatment: water no longer forms large round droplets on the painted surfaces. Depending on use of the car, this may arise after some 3 to 4 months. Do not fail to carry out the necessary protective treatment as soon as it becomes necessary.

If the paintwork tends to lose its high gloss as a result of insufficient care, a suitable **polish\*** must be applied. **Paint cleaner\*** is needed if the finish is already matt or weathered. An abrasive **cutting agent** or **paint restorer\*** should only be used in severe or obstinate cases. Remember that all polishes, cleaners and paint restorers act by removing a layer of paint to expose paint which is still in good condition. Only if the resulting new paint surface is most carefully protected will the overall brilliance of your car's paintwork be regained.

After care of the car's paintwork, remove traces of the products used from the windows with a suitable glass cleaner\*.

\* Obtainable from BMW dealers

**Minor paint damage** can be touched in with either a BMW paint spray aerosol\* or a BMW paint stick\*. The correct colour designation is stated on a label close to the maker's plate, and also on the first page of the Service Booklet.

Damage caused by flying stones, scratches etc. must be touched in without delay, to prevent rust from forming.

If damaged areas of paintwork have already started to rust, use a wire brush to clean them up, and apply a rust converter (protect the eyes and skin). Allow a few minutes for it to take effect, then rinse off with water and dry thoroughly. Apply the primer and allow to dry, then apply the top coat. After a few days, polish the repaired area and apply a paint preservative.

**More extensive paint damage** should be professionally repaired by the BMW service station, which uses only genuine BMW-approved materials in accordance with the manufacturer's instructions.

#### **Important note:**

If a tarpaulin or similar cover is used to protect the car against the weather, moisture condensate may collect, particularly in the case of plastic sheet, and cause the plasticisers to diffuse out of the paint. There is also a risk of scratching the paint surface. It is far better to protect your BMW against ultra-violet rays from bright sunlight and against rainfall etc. by giving it the full body care treatment described here. Ideally, in countries where the sun is extremely hot and powerful, a canvas sunsheet should be stretched 50 to 80 cm (1 - 2 ft) above the car.

**Annual cleaning and protection or treatment** of the engine compartment, underbody, axles and other mechanical assemblies can be carried out with special equipment by a BMW service station. This not only **reduces the risk of serious corrosion** to a minimum, but avoids short-circuits or current leakages and reveals other leaks before they become too severe. This treatment is particularly important at the end of the winter season.

**Chromium-plated and polished metal parts** - bumpers, trim strips, wheel trims etc. - should be cleaned regularly with water to which a car shampoo\* can be added if required. Do not neglect this treatment in winter if salt is spread on the roads.

The **car radio aerial** must be cleaned regularly to ensure good signal reception, and protected against weather effects with the BMW aerial cleaning cloth\*, which is impregnated with a special grease.

**Alloy wheels** should be treated with a special wheel-rim cleanser\*. Do not use aggressive-action products containing acids, strong alkalis or abrasives. Alloy wheels should not be cleaned with a steam jet at a temperature higher than 60°C (140°F).

The **inside surfaces of windows and mirror glasses** can be cleaned and smearing avoided with a special glass cleaner\*. Never clean mirror glasses with polishing pastes or abrasive (quartz) cleansers.

**Plastic components, leatherette upholstery, roof linings, light glasses** and items sprayed matt black should be cleaned with water to which a car shampoo\* may be added. Do not allow the roof lining to become wet right through. If necessary, treat plastic components with a suitable cleanser for synthetic materials\*. Never use solvents such as nitro thinners, cold cleaning agents, fuel etc.

**Rubber components** should only be cleaned with water or treated with a rubber cleanser\* or silicone spray\*.

Clean the **windscreen wiper blades** with soapy water. The wiper blades should be renewed twice a year, before and after the winter season.

**Seat belts** should only be cleaned with a weak soap and water solution, without removing them from the car. Never attempt chemical or dry cleaning, or the belt fabric may be damaged.

**Automatic-reel seat belts** should never be allowed to retract while still wet. Dirt on the belts could prevent them from retracting correctly, thus constituting a safety risk.

**Floor mats and carpets** can be cleaned with an interior cleanser\* if very dirty. Floor mats can be removed for more thorough cleaning of the car's interior.

\* Obtainable from BMW dealers.

### Care of upholstery fabrics

If certain areas of the seats acquire an unwanted gloss after heavy use as a result of heat and moisture, they should be brushed "against the pile" with a slightly moistened brush.

The pile of velour material tends to lie flat in use: as with many furnishing fabrics and clothing materials, this is unavoidable and does not detract from its quality.

Fluff on the upholstery fabric and abraded textile or leather particles are best removed with a suitable fluff brush\* or burr-pile brush\*. Clean off stains or large-area marks at once with lukewarm water, car-interior cleaner\*, stain remover\* or cleaning-grade fuel. Afterwards, brush the fabric to restore its pile.

Seat upholstery fabrics can acquire a **static electrical charge**, particularly when atmospheric humidity is low. Persons touching metal parts of the body **after** leaving the car may then receive an unpleasant but harmless electric shock. Remember to touch an exposed metal part of the car **while getting out**: this will disperse the electric charge without its being noticed.

Antistatic products which largely prevent the build-up of static electricity can be applied if desired.

If the car is parked for a long time in bright sunlight, it is advisable to cover the seats to prevent the colours from bleaching out.

### Care of leather

The **upholstery leather** used in BMW cars is a high-grade natural product treated by the latest processes. If carefully looked after, it will retain its high quality for many years.

Like all natural products, however, due consideration must be given to its properties, to certain limitations in use and to the special care which leather needs.

Regular cleaning and care are essential, since dust and road dirt penetrate the pores and creases, and cause the surface to wear away and become brittle.

If the car is parked for a long time in bright sunlight, it is advisable to cover leather surfaces to prevent the colours from fading, or cover the windows.

Moisten a cotton or woollen cloth slightly with water and clean the leather surface without allowing the seams to become wet through. After drying, the leather should be rubbed down with a soft, clean cloth.

Very dirty areas on leather upholstery can be cleaned with a mild detergent (as sold for woollens) containing no brightening agents. Use 2 tablespoons to one litre (1 3/4 Imp. pints) of water. Dab oil or grease spots carefully with cleaning-grade fuel, but do not rub.

To maintain the condition of the leather after cleaning, and avoid the build-up of a static electrical charge, apply cornelian oil\*. Shake well and apply a thin coating with a soft cloth. Allow to penetrate and dry, then rub with a clean, soft cloth.

It is advisable to repeat this treatment every 6 months if the leather is exposed to normal use.

### Water buffalo leather

Use only a special leather spray\* for regular care, according to its manufacturer's instructions.

Wipe off drops of water immediately, and try to avoid wetting the surface severely (soaking wet clothing, when cleaning etc.).

To remove severe dirt marks, use a mild detergent without brightening agent (2 tablespoons to 1 litre (1 3/4 pints) of water).

Water buffalo leather is left in its natural state and may therefore exhibit areas of slightly varying colour. Natural features such as scars caused by scratches and insect bites, folds in the animal's skin etc. are typical of this material, which acquires a certain patina in use. When new, water buffalo leather may mark light-coloured clothing slightly if moisture is present.

\* Obtainable from BMW dealers

**Engine data, fuel consumption**

		<b>BMW 520 i</b>		<b>BMW 520 i ECE version</b>		<b>BMW 525 i</b>	
<b>Displacement – effective</b>	cm <sup>3</sup>	1990		1990		2494	
<b>Number of cylinders</b>				6			
<b>Max. output</b>	kW	95		95		125	
(DIN 70 020 standard)	bhp	129		129		170	
– at engine speed	1/min	6000		6000		5800	
<b>Max. torque</b>	Nm	164		174		222	
	lb. ft	121		128		164	
– at engine speed	1/min	4300		4000		4300	
<b>Compression ratio</b>	: 1	8.8		9.4		8.8	
<b>Stroke/bore</b>	mm	66/80		66/80		75/84	
<b>Mixture preparation</b>		Digital Motor Electronics					
<b>Fuel consumption</b>		5-speed	Auto-	5-speed	Auto-	5-speed	Auto-
(DIN 70 030/1 ECE		gearbox	matic	gearbox	matic	gearbox	matic
standard test method)							
At 90 km/h	l/100 km	7.5/ 7.4*	7.7/ 7.5*	6.8	6.9	7.0/ 6.8*	7.2/ 6.9*
(56 mile/h)	(imp. mile/gal)	37.7/38.2*	36.7/37.7*	41.5	40.9	40.3/41.5*	39.2/40.9*
At 120 km/h	l/100 km	9.2/ 8.8*	9.4/ 8.9*	8.7	8.7	8.5/ 8.1*	8.8/ 8.3*
(75 mile/h)	(imp. mile/gal)	30.7/21.1*	30.1/31.7*	29.4	29.4	33.2/34.9*	32.1/34.0*
Urban driving cycle	l/100 km	13.6/13.5*	13.9/13.5*	13.4	13.3	13.1/12.9*	13.3/13.1*
	(imp. mile/gal)	20.8/20.9*	20.3/20.9*	21.1	21.2	21.6/21.9*	21.2/21.6*

\* without catalytic converter

**Engine data, fuel consumption**

		<b>BMW 530 i</b>		<b>BMW 535 i</b>		<b>BMW 524 td</b>	
<b>Displacement – effective</b>	cm <sup>3</sup>	2986		3430		2443	
<b>Number of cylinders</b>				6			
<b>Max. output</b>	kW	138		155		85	
(DIN 70 020 standard)	bhp	188		211		115	
– at engine speed	1/min	5800		5700		4800	
<b>Max. torque</b>	Nm	260		305		220	
	lb.ft	192		225		162	
– at engine speed	1/min	4000				2400	
<b>Compression ratio</b>	: 1	9.0				22.0	
<b>Stroke/bore</b>	mm	80/89		86/92		81/80	
<b>Mixture preparation</b>		Digital Motor Electronics				Digital Diesel Electronics	
<b>Fuel consumption</b>		5-speed		5-speed		5-speed	
(DIN 70 030/1 ECE		gearbox		gearbox		gearbox	
standard test method)		Auto-		Auto-		Auto-	
		matic		matic		matic	
At 90 km/h	l/100 km	7.4/ 7.4*	7.4/ 7.3*	7.6/ 7.6*	7.6/ 7.6*	Values not available at time of going to press	
(56 mile/h)	(Imp. mile/gal)	38.2/38.2*	38.2/38.7*	37.2/37.2*	37.2/37.2*		
At 120 km/h	l/100 km	9.2/ 9.1*	9.2/ 9.1*	9.6/ 9.6*	9.6/ 9.5*		
(75 mile/h)	(Imp. mile/gal)	30.7/31.0*	30.7/31.0*	29.4/29.4*	29.4/29.7*		
Urban driving cycle	l/100 km	15.9/15.4*	16.8/16.4*	16.6/15.8*	17.4/16.6*		
	(Imp. mile/gal)	17.8/18.3*	16.8/17.2*	17.0/17.9*	16.2/17.0*		

\* without catalytic converter

## Dimensions and weights

		BMW 520 i	BMW 525 i	BMW 530 i	BMW 535 i	BMW 524 td
Length	mm			4720 (185.8 in)		
Width	mm			1751 (68.9 in)		
Height (unladen)	mm			1412 (55.6 in)		
Wheelbase	mm			2761 (108.7 in)		
Front overhang	mm			846 (33.3 in)		
Rear overhang	mm			1113 (43.8 in)		
Front track (at axle load limit)	mm			1466 (57.7 in)		
Rear track (at axle load limit)	mm			1487 (61.0 in)		
Min. turning circle (wheels) app.	m			app. 10.8 m (35 ft 5 in)		
Min. turning circle (overall) app.	m			app. 11.5 m (37 ft 9 in)		
Unladen weight (ready to drive, full tank, without special equipment) - without automatic transmission	kg	1400 (3086 lb)	1450 (3197 lb)	1510 (3329 lb)	1525 (3362 lb)	1480 (3263 lb)
	kg	1420 (3131 lb)	1470 (3241 lb)	1530 (3373 lb)	1545 (3406 lb)	1500 (3307 lb)
Gross weight limit - with automatic transmission	kg	1910 (4211 lb)	1960 (4321 lb)	2020 (4453 lb)	2035 (4486 lb)	1990 (4387 lb)
	kg	1930 (4255 lb)	1980 (4365 lb)	2040 (4497 lb)	2055 (4530 lb)	2010 (4431 lb)
Front axle load limit	kg	930 (2050 lb)	950 (2094 lb)	975 (2149 lb)	975 (2149 lb)	975 (2149 lb)
Rear axle load limit	kg	1100 (2425 lb)	1130 (2491 lb)	1165 (2568 lb)	1175 (2590 lb)	1135 (2502 lb)
Trailer load limits (specified by factory, or as laid down by law in the Federal Republic of Germany)						
unbraked	kg	650 (1433 lb)	700 (1543 lb)	700 (1543 lb)	700 (1543 lb)	650 (1433 lb)
braked, max. gradient 12 % (1 in 8.3)	kg	1400 (3086 lb)	1500 (3307 lb)	1600 (3527 lb)	1600 (3527 lb)	1500 (3307 lb)
Please consult a BMW service station with regard to higher trailer load limits						
Max. towbar downthrust		50 kg (110 lb); with trailer towing or self-levelling suspension options 75 kg (165 lb)				
Max. roof load (do not exceed max. axle loads or gross weight limit when carrying loads on roof)		100 kg (220 lb)				
Luggage capacity acc. to VDA test		460 litres (16.2 cu. ft)				

## Performance

		BMW 520 i	BMW 520 i ECE version	BMW 525 i
<b>Top speed</b>	km/h (mile/h)	203 (126)	203 (126)	221 (137)
	- with automatic transmission	198 (123)	200 (124)	217 (135)
<b>Acceleration</b>	km/h (mile/h)	s	s	s
	0- 50	4.0	3.8	2.9
	0- 80	7.8	7.5	6.4
	0-100	11.9/13.9*	11.4/13.3*	9.5/11.3*
	0-120	16.6	16.1	13.2
80-120 km/h (50-75 mile/h) in direct gearbox ratio		12.6	11.2	11.6
Standing-start kilometre		32.8/35.5*	32.6/34.7*	30.5/32.3*

\* With automatic transmission

Note: engine and road performance are measured according to the appropriate DIN standard (with the vehicle to standard equipment specification). Permissible deviations are also taken into account.

Additional equipment or optional extras can have a significant effect on consumption and performance figures, since the car's weight and drag coefficient are usually altered (roof rack, wider tyres, additional mirrors).

**Performance**

		<b>BMW 530 i</b>	<b>BMW 535 i</b>	<b>BMW 524 td</b>
<b>Top speed</b> - with automatic transmission	km/h (mile/h)	227 (141)	235 (146)	192 (119)
		224 (139)	231 (144)	190 (118)
<b>Acceleration</b>	km/h (mile/h) s		s	s
	0- 50/0-31	2.6	2.5	4.2
	0- 80/0-50	5.7	5.3	8.3
	0-100/0-62	8.6/10.8*	7.7/9.1*	12.9/13.9*
	0-120/0-75	12.0	10.9	18.4
80-120 km/h (50-75 mile/h) in direct gearbox ratio		10.9	9.7	12.9
<b>Standing-start kilometre</b>		29.4/31.6*	28.5/29.7*	34.3/35.5*

\* With automatic transmission.

**Technical data****Gear ratios**

	5-speed-gearbox		Automatic transmission		
	520 i	524 td	524 td		
1st	3.83	3.72	4.35	2.48	2.73
2nd	2.20	2.04	2.33	1.48	1.56
3rd	1.40	1.30	1.39	1.00	1.00
4th	1.00	1.00	1.00	0.73	0.73
5th	0.81	0.80	0.81	-	-
Reverse	3.46	3.45	3.73	2.09	2.09

**Electrical system****Battery**

BMW 520 i, 525 i	12 V, 50 Ah
BMW 530 i, 535 i	12 V, 75 Ah*
BMW 524 td	12 V, 85 Ah*

\* located beneath rear seat

**Firing order**

1-5-3-6-2-4

**Ignition timing**

On cars equipped with Digital Motor Electronics, ignition timing is pre-programmed and cannot be adjusted.

**Alternator**

BMW 520 i, 525 i	80 A, 1120 W
BMW 530 i, 535 i	90 A, 1260 W

with built-in voltage regulator

**Index**

- Acceleration values 99
- Acid level 66
- Adjustable shock absorbers 35
- Aerial 52, 94
- Aerial cleaning 52, 94
- Airbag 15
- Air conditioning 32
- Alternator 101
- Antifreeze 79
- Antilock brake system 90
  - warning light 23
- Armrest 39
- ASC 35, 91
- ASC defective 35**
- Ashtrays 36
- Automatic Stability Control 35, 91
- Automatic transmission 28
  - oil content 110
  - oil level check 63
  - ratios 101
  - selector lever position indicator 28
- Axle load limits 98
  
- Battery 66, 68, 101
- Battery acid level 66
- Battery charge telltale 23
- Body cavity sealing 92
- Body dimensions 98
- Body overhang 98
- Body protection treatment 94
- Brake hydraulics warning lamp 23, 72
- Brake fluid 64
- Brake fluid 64, 72**
- Brake light 24**
- Brake lights 76
- Brake linings 72**
- Brakes 56, 72, 82
- Bulb changing 75
- Burglar alarm 43
  
- Caravan towing 88
- Car radio 52
- Care of car 92
- Catalytic converter 55, 57
- Central locking system 7
- Check Control 24
- Check Control 25**
- Childproof door locks 8
- Child restraint system 14
- Chromium, care of 94
- Cigarette lighter 37
- Clock 36
- Cold starting 54, 57
- Cold weather operation 79
- Compression ratio 96
- Computer, on-board 44
- Coolant 79
- Coolant level, checking 65**
- Coolant tank 65
- Coolant temperature 22**
- Coolant temperature gauge 22
- Cooling system 65, 79
- Cooling system capacity 110
- Corrosion protection 93
- Cruise control 42
  
- Defrosting windows 30
- Diesel model,
  - wintertime operation 79
- Differential, see Final drive
- Dimensions 98
- Dipped beams 17, 75
- Dipstick 62
- Disc brakes 82
- Displacement (engine) 96
- Door lock heating 7
- Door locks 7
- Door mirrors 16
- Door safety catches 8
- Driving hints 57, 80, 82
- Dust caps (tyre valves) 84
  
- Economy 54
- Electrical system 101
- Energy Control 21
- Engine capacity 96
- Engine compartment lid 58
- Engine compartment light 58, 77
- Engine compartment, principal components 59
- Engine data 96
- Engine oil consumption 62
- Engine oil content 110
- Engine oil grades 62
- Engine oil level, checking 62**
- Engine oil pressure 24, 62**
- Engine power output 96
- Engine specifications 96
- Engine torque 96
  
- Filling capacities 110
- Final drive oil content 110
- Fire extinguisher 70
- Firing order 101
- First aid box 70
- Flat battery 68
- Fog light, rear 26, 76
- Fog lights, front 26, 75
  - cleaning system 20, 65
- Front/rear balance control 53
- Front seat adjustment 11
- Front seat adjustment, electrical 12
- Fuel 4, 57
- Fuel consumption 54, 57, 96
- Fuel consumption indicator 21
- Fuel economy 54
- Fuel filler flap 4, 8
- Fuel gauge 22
- Fuel tank capacity 110
- Fuel telltale lamp 22
- Fuses 67
  
- Gearbox (manual) 27

Gearbox gate pattern 27  
 Gearbox oil capacity 110  
 Gearbox ratios 101  
 Glove box 37

Hand lamp, rechargeable 37  
 Handbrake 27, 56  
 Hazard warning flashers 26  
 Head restraints 11, 13  
 Headlight and side light switch 17  
 Headlight beam throw adjuster 75  
 Headlight cleaning system 20  
 Headlight cleaning system tank 65  
 Headlight flasher 19  
 Headlights 75  
 Heated rear window 26  
 Heater/ventilation, independent 41  
 Heating/ventilation 30  
 Height 98  
 High beam headlights 19, 75  
 Horn 20

Ignition/starter switch 17  
 Ignition timing 101  
 Infra-red remote control 9  
 Instrument lighting 17  
 Instruments 18  
 Intensive cleaning system 20  
 Intensive cleaning system tank 65  
 Interior lights 36, 77  
 Interior mirror 16

Jack 70

Keys 7  
 Kickdown 29

Laying up out of use 79  
 Leather care 95  
 Length 98  
 Licence plate light 77

Light switch 17  
 Limited-slip differential 91  
 Low beam headlights 17, 75  
 Luggage compartment capacity 98  
 Luggage compartment lid 8  
 Luggage compartment light 8, 77  
 Lumbar support 13

Main beam 19, 75  
 Maker's plate 59  
 Make-up mirror 16  
 Memory for seat/mirror 12  
 Minor repairs 68  
 Mirrors, outside 16  
 Modifications 86

Number plate lights 77

Octane number 4  
 Oil additives 62  
 Oil consumption 62  
 Oil content 110  
 Oil grades 62, 110  
 Oil level, checking 62  
**Oil level sensor 25**  
**Oil pressure sensor 25**  
 Oil pressure telltale 23  
 On-board computer 44  
 Outside temperature display and  
 digital clock 40  
 Overhang 98

Paintwork, care of 79, 92  
 Paintwork damage 92  
 Parking lights 20, 75  
 Performance 96  
 Performance, engine 96  
 Power output 96  
 Power steering 64, 70, 73  
 - oil level check 64  
 Punctures 70

Radial ply tyres 80, 83  
 Radiator cap 65  
 Radiator header tank 65  
 Radio 52  
 Radio aerial 52, 94  
 Reading lights 36, 77  
 Rear fog lights 26, 76  
 Rear lights 76  
 Refuelling 4  
 Remote control 9  
 Re-registration abroad 87  
 Reversing lights 27, 76  
 Revolution counter 21  
 Rims 85  
 Roof load limit 98  
 Roof rack 87  
 Rubber components 79, 94  
 Running-in 56

Seat adjustment 11  
 Seat adjustment, electric 12  
 Seat belts 14, 94  
 Seat heating 39  
 Seat/mirror memory 12  
 Selector lever position indicator 28  
 Self-levelling suspension, oil level 64  
 Service Indicator 25  
 Side lights 17, 75  
 Shock absorbers, adjustable 35  
 Ski bag 50  
 Sliding/vent roof 38, 74  
 Snow chains 81, 85  
 Spark plugs 112  
 Spare wheel 70  
 Specifications 96  
 Speedometer 21  
 Speed control 42  
 Sports suspension 88  
 Starting aids 68  
 Starting the engine 54  
 Starting with flat battery 78

Steering lock 17  
 Steering wheel reach adjustment 13  
 Stop lights 76  
 Sun visors 16

Technical data 96  
 Technical modifications 86  
 Telltale lamps 23  
 Thermometer, coolant 22  
 Thiefproofing device 7  
 Time switch 41  
 Toolkit 68  
 Top speed 99  
 Torch, rechargeable 37  
 Torque 96  
 Tow starting 69  
 Towbar downthrust 98  
 Towing a trailer 88  
 Towing away 69  
 Towing eyes 69  
 Track 98  
 Trailer load 98  
 Trailer nose weight 98  
 Trailer towing 88  
**Trans. program** 29  
 Triangle, warning 68  
 Trip distance recorder 21  
 Turn indicator repeater 17, 79  
 Turn indicators 19  
 Turning circle 98  
 Type plate 59  
 Tyre pressures 111, 112  
 Tyre repairs 71  
 Tyre tread 83  
 Tyre valve caps 84  
 Tyres 80, 83  
 Tyres, fitting new 84

Underseal 94

V-belts 112

Vehicle identification number 59  
 Ventilation 30

Warning lamps 23  
 Warning lamp for brake hydraulics 23, 72  
 Warning triangle 68  
 Weights 98  
 Wheel-changing 70  
 Wheel chock 70  
 Wheel stud wrench 70  
 Wheel studs, lockable 72  
 Wheelbase 98  
 Wheels 85  
 Wheels, interchanging 84  
 Width 98  
 Window lifts, electric 38  
 Windscreen wash/wipe 20  
 Windscreen washer fluid tank 65  
 Windscreen washer jets 66  
 Windscreen wipers 20  
 Windscreen wiper blades 74, 94  
 Winter operation 79  
 Winter tyres 80, 85



**Note: for items in bold type, the Check Control displays "OWNER'S HANDBOOK".**

<b>Filling capacities</b>	Litres (Imp. units)	Notes
Fuel tank	80 (17.6 gal)	Fuel grade: see Page 4
Windscreen washer in conjunction with headlight and fog light cleaning system Headlight and fog light cleaning system intensive cleaning system	app. 4.0 (7.9 pints) (BMW 524 td: app. 3.7) (6.5 pints) app. 8.5 (15.3 pints) – BMW 520 i, 525 i app. 9.0 (15.8 pints) – BMW 524 td app. 8.0 (14.1 pints) – BMW 530 i, 535 i app. 1.0 (1.8 pints)	For details, see Page 65
Cooling system including heater	10.5 (18.5 pints) – BMW 520 i, 525 i 11.0 (19.4 pints) – with air conditioning 12.0 (21.1 pints) – BMW 530 i, 535 i, 524 td	For details, see Page 65
Engine with/without oil filter renewal	4.25/4.00 (7.5/7.0 pints) – BMW 520 i 4.75/4.50 (8.4/7.9 pints) – BMW 525 i 5.75/5.00 (10.1/8.8 pints) – BMW 530 i, 535 i 5.25/4.50 (9.2/7.9 pints) – BMW 524 td	Brand-name HD oil for spark-ignition engines; see Page 62 for oil grades
Gearbox (manual)	1.15 (2.0 pints) – BMW 520 i, 524 td* 1.25 (2.2 pints) – BMW 525 i, 530 i, 535 i	Brand-name SAE 80 gear oil to MIL-L-2105 A or API-GL 4 specification; alternatively single-grade SAE 20/30/40 HD mineral-based engine oil to API-SE or -SF specification BMW 524 td: ATF*
Automatic transmission	3.0 (5.3 pints)	ATF*
Final drive (rear axle)	1.7 (3.0 pints) – BMW 520 i, 525 i, 530 i, 524 td 1.9 (3.3 pints) – BMW 535 i	Brand-name hypoid gear oil, SAE 90*

\* Authorised BMW service stations know the correct grades

### For your safety – check tyre pressures regularly

Tyre pressures in bar (gauge pressure) when cold (ambient temperature); values in brackets = lb/in<sup>2</sup> (psi).  
**Note:** as the tyres become hot (e. g. fast main-road driving), pressure rises by approx. 0.3 bar (app. 4.0 lb/in<sup>2</sup>).  
 For every change in temperature of 10° C, tyre pressure varies by 0.1 bar (1.4 lb/in<sup>2</sup>).

BMW model	Radial-ply tyres (tubeless)				
520i	205/65 R 15 94 H 225/60 R 15 95 H TD 230/55 VR 390 TD 230/55 R 390 94 V 240/45 VR 415 240/45 R 415 94 V	2.0 (28)	2.1 (30)	2.1 (30)	2.6 (37)
	195/65 R 15 91 H 195/65 R 15 91 Q M+S 205/65 R 15 93 Q/T M+S 225/60 R 15 95 Q/T/H M+S 240/45 R 415 94 H M+S TD 230/55 R 390 94 Q/T/H M+S	2.0 (28)	2.3 (33)	2.3 (33)	2.8 (40)
	195/65 R 15 91 T M+S 200/60 R 390 90 Q/T M+S 220/55 R 390 93 H M+S 205/65 R 15 93 H M+S	2.2 (31)	2.5 (36)	2.5 (36)	3.0 (43)
525i	205/65 R 15 94 V 205/65 VR 15 225/60 R 15 95 V 225/60 VR 15 240/45 R 415 94 V 240/45 VR 415 TD 230/55 R 390 94 V TD 230/55 VR 390	2.0 (28)	2.3 (33)	2.4 (34)	2.9 (41)
	195/65 VR 15 195/65 R 15 91 V 195/65 R 15 91 Q/T M+S 205/65 R 15 93 Q/T/H M+S 225/60 R 15 95 Q/T/H M+S TD 230/55 R 390 94 Q/T/H M+S 200/60 R 390 Q/T M+S 220/55 R 390 93 H M+S 240/45 R 415 94 H M+S	2.2 (31)	2.6 (37)	2.7 (38)	3.2 (46)

**Spark plugs**

Bosch W 8 LCR

Heat value  
145**V-belts****Alternator and coolant pump**

BMW 520i, 525i, 524td 9.5 x 983 mm  
 BMW 530i, 535i 12.5 x 1055 mm

**Hydraulic power steering pump**



BMW 520i, 525i, 524td 9.5 x 820 mm  
 BMW 530i, 535i 9.5 x 865 mm

**Air conditioning compressor**

BMW 520i, 525i 12.5 x 810 mm  
 BMW 530i, 535i 12.5 x 860 mm  
 BMW 524td 13.0 x 815 mm

**For your safety – check tyre pressures regularly**

**Tyre pressures** in bar (gauge pressure) when cold (ambient temperature); values in brackets = lb/in<sup>2</sup> (psi).  
**Note:** as the tyres become hot (e. g. fast main-road driving), pressure rises by approx. 0.3 bar (app. 4.0 lb/in<sup>2</sup>).  
 For every change in temperature of 10°C, tyre pressure varies by 0.1 bar (1.4 lb/in<sup>2</sup>).

BMW model	Radial-ply tyres (tubeless)				
530i	205/65 R 15 94 V 205/65 VR 15 225/60 R 15 95 V 225/60 VR 15 240/45 R 415 94 V 240/45 VR 415 TD 230/55 R 390 94 V TD 230/55 VR 390	2.0 (28)	2.2 (31)	2.4 (34)	3.0 (43)
	205/65 R 15 93 Q/T/H M+S 225/60 R 15 95 Q/T/H M+S TD 230/55 R 390 94 Q/T/H M+S 220/55 R 390 93 H M+S 240/45 R 415 94 H M+S	2.2 (31)	2.4 (34)	2.6 (37)	3.2 (46)
535i	225/60 ZR 15 225/60 VR 15 TD 230/55 ZR 390 TD 230/55 VR 390 240/45 ZR 415 240/45 VR 415 205/65 R 15 93 Q/T/H M+S 225/60 R 15 95 Q/T/H M+S TD 230/55 R 390 94 Q/T/H M+S 220/55 R 390 93 H M+S 240/45 R 415 94 H M+S	2.0 (28)	2.4 (34)	2.7 (38)	3.2 (46)

A label showing tyre pressures for special model versions is attached to the driver's door post.